

Multilayer Ceramic Capacitor - Axial Leded Type

Features

- Superior moisture and shock resistant epoxy coating
- Available in tape & reel, or ammo package
- Ideal for automatic insertion in printed circuit board
- RoHS compliant



Applications

- Bypassing
- Coupling and Decoupling
- Filtering



Dimensions (in mm)

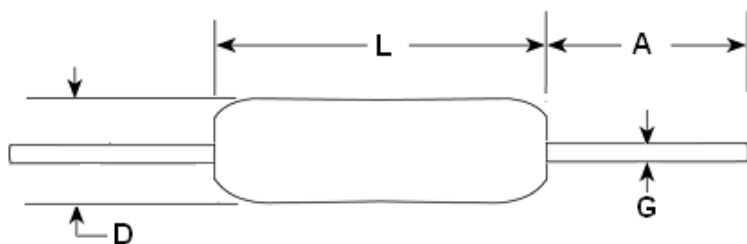

Unit: mm

| Size | Chip Size | L Max. | D Max. | A Min. | G |
|------|-----------|--------|--------|--------|----------|
| S | 0603/0805 | 3.5 | 2.54 | 25.4 | 0.5±0.05 |
| M | 1206 | 5.0 | 3.0 | 25.4 | 0.5±0.05 |

Multilayer Ceramic Capacitor - Axial Leded Type

TMA Series

Class I: NPO Dielectric

| Description | Symbol | Value | Condition |
|------------------------------|------------------|--|---|
| Operation Temperature Range | T _{OP} | -55 ~ +125 °C | |
| Temperature Coefficient | | 0 ± 30 ppm/°C | |
| Capacitance Range | C _R | 10 pF ~ 1,000 pF | 1 ± 0.2 Vrms at 25°C and 1MHz |
| | | 1,200 pF ~0.01μF | 1 ± 0.2 Vrms at 25°C and 1KHz |
| Capacitance Tolerance | | ± 5%(J) | |
| Rated Voltage | U _{RDC} | 50/100/200V | |
| Max. Dissipation Factor | tan δ | 0.1% | 1 ± 0.2 Vrms at 25°C and 1MHz for 10 pF ~ 1,000 pF |
| | | | 1 ± 0.2 Vrms at 25°C and 1KHz for 1,200 pF ~0.01μF |
| Insulation Resistance (Note) | R _{INS} | ≥10 GΩ or 500 MΩ*μF Whichever is less | Rated voltage applied at 25°C, Test Time: 120 sec |
| Withstanding Voltage | U _{OL} | 2.5 x U _R | Charging/discharging Current < 50mA for 1 ~5 sec |

Note: For example, IR(.47μF)=500MΩ*μF=500MΩ*(1/.47μF)(μF)=500MΩ*2.13=1064MΩ=1.06GΩ.

Size and Capitance Specifications

| Cap. Value | Cap. Code | S | | | M | | | Cap. Value | Cap. Code | S | | | M | | |
|------------|-----------|-----|------|------|-----|------|------|------------|-----------|-----|------|------|-----|------|------|
| | | 50V | 100V | 200V | 50V | 100V | 200V | | | 50V | 100V | 200V | 50V | 100V | 200V |
| 10 pF | 100 | | | | | | | 560 pF | 561 | | | | | | |
| 18 pF | 180 | | | | | | | 1000 pF | 102 | | | | | | |
| 22 pF | 220 | | | | | | | 1200 pF | 122 | | | | | | |
| 30 pF | 300 | | | | | | | 1500 pF | 152 | | | | | | |
| 33 pF | 330 | | | | | | | 2200 pF | 222 | | | | | | |
| 39 pF | 390 | | | | | | | 2700 pF | 272 | | | | | | |
| 47 pF | 470 | | | | | | | 3300 pF | 332 | | | | | | |
| 56 pF | 560 | | | | | | | 3900 pF | 392 | | | | | | |
| 68 pF | 680 | | | | | | | 4700 pF | 472 | | | | | | |
| 100 pF | 101 | | | | | | | 5600 pF | 562 | | | | | | |
| 180 pF | 181 | | | | | | | 6800 pF | 682 | | | | | | |
| 220 pF | 221 | | | | | | | 8200 pF | 822 | | | | | | |
| 390 pF | 391 | | | | | | | 0.01 μF | 103 | | | | | | |
| 470 pF | 471 | | | | | | | | | | | | | | |

Note: Please consult factory if other capacitance or tolerance or voltage is required.

Multilayer Ceramic Capacitor - Axial Leaded Type

TMA Series

Class II: X7R Dielectric

| Description | Symbol | Value | Condition |
|------------------------------|------------------|--|---|
| Operation Temperature Range | T _{OP} | -55 ~ +125 °C | |
| Temperature Coefficient | ΔC/C(25°C) | ± 15% | |
| Capacitance Range | C _R | 220 pF ~10 μF | 1 ± 0.2 Vrms at 25°C and 1KHz |
| Capacitance Tolerance | | ± 5%(J), 10%(K), 20%(M) | |
| Rated Voltage | U _R | 50/100/200V | |
| Max. Dissipation Factor | tan δ | 3.0% | 1 ± 0.2 Vrms at 25°C and 1KHz |
| Insulation Resistance (Note) | R _{INS} | ≥10 GΩ or 500 MΩ*μF Whichever is less | Rated voltage applied at 25°C Test Time: 120 sec |
| Withstanding Voltage | U _{OL} | 2.5 x U _R | Charging/discharging Current < 50mA for 1 ~5 sec |

Note: For example, IR(.47μF)=500MΩ*μF=500MΩ*(1/.47μF)(μF)=500MΩ*2.13=1064MΩ=1.06GΩ.

Size and Capitance Specifications

| Cap. Value | Cap. Code | S | | | M | | | Cap. Value | Cap. Code | S | | | M | | |
|------------|-----------|-----|------|------|-----|------|------|------------|-----------|-----|------|------|-----|------|------|
| | | 50V | 100V | 200V | 50V | 100V | 200V | | | 50V | 100V | 200V | 50V | 100V | 200V |
| 220 pF | 221 | | | | | | | 0.022 μF | 223 | | | | | | |
| 390 pF | 391 | | | | | | | 0.027 μF | 273 | | | | | | |
| 470 pF | 471 | | | | | | | 0.033 μF | 333 | | | | | | |
| 560 pF | 561 | | | | | | | 0.039 μF | 393 | | | | | | |
| 1000 pF | 102 | | | | | | | 0.047 μF | 473 | | | | | | |
| 1200 pF | 122 | | | | | | | 0.056 μF | 563 | | | | | | |
| 1500 pF | 152 | | | | | | | 0.068 μF | 683 | | | | | | |
| 2200 pF | 222 | | | | | | | 0.082 μF | 823 | | | | | | |
| 2700 pF | 272 | | | | | | | 0.1 μF | 104 | | | | | | |
| 3300 pF | 332 | | | | | | | 0.15 μF | 154 | | | | | | |
| 3900 pF | 392 | | | | | | | 0.18 μF | 184 | | | | | | |
| 4700 pF | 472 | | | | | | | 0.22 μF | 224 | | | | | | |
| 5600 pF | 562 | | | | | | | 0.33 μF | 334 | | | | | | |
| 6800 pF | 682 | | | | | | | 0.47 μF | 474 | | | | | | |
| 8200 pF | 822 | | | | | | | 0.68 μF | 684 | | | | | | |
| 0.01 μF | 103 | | | | | | | 1.0 μF | 105 | | | | | | |
| 0.012 μF | 123 | | | | | | | 2.2 μF | 225 | | | | | | |
| 0.015 μF | 153 | | | | | | | 10 μF | 106 | | | | | | |

Note: Please consult factory if other capacitance or tolerance or voltage is required.

Multilayer Ceramic Capacitor - Axial Leaded Type

TMA Series

Class II: Y5V Dielectric

| Description | Symbol | Value | Condition |
|------------------------------|------------------|--|---|
| Operation Temperature Range | T _{OP} | -30 ~ +85 °C | |
| Temperature Coefficient | ΔC/C(25°C) | - 82% ~+ 22% | |
| Capacitance Range | C _R | 1000 pF ~ 10 μF | 1 ± 0.2 Vrms at 25°C and 1KHz |
| Capacitance Tolerance | | ± 20%(M), +80%/-20%(Z) | |
| Rated Voltage | U _R | 50/100V | |
| Max. Dissipation Factor | tan δ | 5.0% | 1 ± 0.2 Vrms at 25°C and 1KHz |
| Insulation Resistance (Note) | R _{INS} | ≥10 GΩ or 100 MΩ*μF Whichever is less | Rated voltage applied at 25°C Test Time: 120 sec |
| Withstanding Voltage | U _{OL} | 2.5 x U _R | Charging/discharging Current < 50mA for 1 ~5 sec |

Note: For example, IR(.47μF)=500MΩ*μF=500MΩ*(1/.47μF)(μF)=500MΩ*2.13=1064MΩ=1.06GΩ.

Size and Capitance Specifications

| Cap. Value | Cap. Code | S | | Cap. Value | Cap. Code | S | |
|------------|-----------|-----|------|------------|-----------|-----|------|
| | | 50V | 100V | | | 50V | 100V |
| 1000 pF | 102 | | | 0.033 μF | 333 | | |
| 1200 pF | 122 | | | 0.039 μF | 393 | | |
| 1500 pF | 152 | | | 0.047 μF | 473 | | |
| 2200 pF | 222 | | | 0.056 μF | 563 | | |
| 2700 pF | 272 | | | 0.068 μF | 683 | | |
| 3300 pF | 332 | | | 0.082 μF | 823 | | |
| 3900 pF | 392 | | | 0.1 μF | 104 | | |
| 4700 pF | 472 | | | 0.15 μF | 154 | | |
| 5600 pF | 562 | | | 0.18 μF | 184 | | |
| 6800 pF | 682 | | | 0.22 μF | 224 | | |
| 8200 pF | 822 | | | 0.33 μF | 334 | | |
| 0.01 μF | 103 | | | 0.47 μF | 474 | | |
| 0.012 μF | 123 | | | 0.68 μF | 684 | | |
| 0.015 μF | 153 | | | 1.0 μF | 105 | | |
| 0.022 μF | 223 | | | 2.2 μF | 225 | | |
| 0.027 μF | 273 | | | 10 μF | 106 | | |

Note: Please consult factory if other capacitance or tolerance or voltage is required.

Multilayer Ceramic Capacitor - Axial Leded Type

TMA Series

Reliability Test Condition

| No | Item | Performance | Test Condition | | | | | | | | | | | | | | | | | | | | | | | | | | | | | | | | | | | | |
|---------------|--|---|---|-----|-----|-----|--------------|--|------------------|-----------------|--|---------------------------------------|--|--|----|--|--|--|--|-----------|-----|-----|-----|-------------|------------------------|--|-----------------------|------|------------|--|--|---------|----------------------------|--|--|---------------|-----------------|--|--|
| 1 | Solderability | Lead wire shall be soldered with uniformly coated on the Axial or Radial direction over 95% of the circumferential direction. | The lead wire of a capacitor shall be dipped into a rosin and then into molten solder of $235\pm 5^{\circ}\text{C}$ for 5 seconds, in both cases the depth of dipping is up to about 2.5 to 3.0 mm from the root of lead wires. | | | | | | | | | | | | | | | | | | | | | | | | | | | | | | | | | | | | |
| 2 | Resistance to Soldering Heat | 1. Appearance: No marked defect 2. Capacitance change: <table border="1"> <thead> <tr> <th></th> <th>NPO</th> <th>X7R</th> <th>Y5V</th> </tr> </thead> <tbody> <tr> <td>$\Delta C/C$</td> <td>$\leq \pm 0.5\%$, or $\pm 0.5\text{pF}$</td> <td>$\leq \pm 7.5\%$</td> <td>$\leq \pm 20\%$</td> </tr> </tbody> </table> | | NPO | X7R | Y5V | $\Delta C/C$ | $\leq \pm 0.5\%$, or $\pm 0.5\text{pF}$ | $\leq \pm 7.5\%$ | $\leq \pm 20\%$ | The lead wire shall be immersed into the melted solder of $265\pm 5^{\circ}\text{C}$, up to about 2.5 to 3.0 mm from the main body and the specified items shall be measured after leaving for 24 ± 2 hours. | | | | | | | | | | | | | | | | | | | | | | | | | | | | |
| | NPO | X7R | Y5V | | | | | | | | | | | | | | | | | | | | | | | | | | | | | | | | | | | | |
| $\Delta C/C$ | $\leq \pm 0.5\%$, or $\pm 0.5\text{pF}$ | $\leq \pm 7.5\%$ | $\leq \pm 20\%$ | | | | | | | | | | | | | | | | | | | | | | | | | | | | | | | | | | | | |
| 3 | Life Test | 1. Appearance: No marked defect 2. Change value: <table border="1"> <thead> <tr> <th></th> <th>NPO</th> <th>X7R</th> <th>Y5V</th> </tr> </thead> <tbody> <tr> <td>$\Delta C/C$</td> <td>$\leq \pm 2\%$, or $\pm 2\text{pF}$</td> <td>$\leq \pm 10\%$</td> <td>$\leq \pm 30\%$</td> </tr> <tr> <td>DF</td> <td colspan="3">$\leq 1.5 \times$ initial requirement</td> </tr> <tr> <td>IR</td> <td colspan="3">$\geq 0.25 \times$ initial requirement</td> </tr> </tbody> </table> | | NPO | X7R | Y5V | $\Delta C/C$ | $\leq \pm 2\%$, or $\pm 2\text{pF}$ | $\leq \pm 10\%$ | $\leq \pm 30\%$ | DF | $\leq 1.5 \times$ initial requirement | | | IR | $\geq 0.25 \times$ initial requirement | | | <table border="1"> <thead> <tr> <th>Condition</th> <th>NPO</th> <th>X7R</th> <th>Y5V</th> </tr> </thead> <tbody> <tr> <td>Temperature</td> <td colspan="2">$+125^{\circ}\text{C}$</td> <td>$+85^{\circ}\text{C}$</td> </tr> <tr> <td>Time</td> <td colspan="3">1000 hours</td> </tr> <tr> <td>Voltage</td> <td colspan="3">1.5x rated voltage applied</td> </tr> <tr> <td>Recovery time</td> <td colspan="3">24 ± 2 hours</td> </tr> </tbody> </table> | Condition | NPO | X7R | Y5V | Temperature | $+125^{\circ}\text{C}$ | | $+85^{\circ}\text{C}$ | Time | 1000 hours | | | Voltage | 1.5x rated voltage applied | | | Recovery time | 24 ± 2 hours | | |
| | NPO | X7R | Y5V | | | | | | | | | | | | | | | | | | | | | | | | | | | | | | | | | | | | |
| $\Delta C/C$ | $\leq \pm 2\%$, or $\pm 2\text{pF}$ | $\leq \pm 10\%$ | $\leq \pm 30\%$ | | | | | | | | | | | | | | | | | | | | | | | | | | | | | | | | | | | | |
| DF | $\leq 1.5 \times$ initial requirement | | | | | | | | | | | | | | | | | | | | | | | | | | | | | | | | | | | | | | |
| IR | $\geq 0.25 \times$ initial requirement | | | | | | | | | | | | | | | | | | | | | | | | | | | | | | | | | | | | | | |
| Condition | NPO | X7R | Y5V | | | | | | | | | | | | | | | | | | | | | | | | | | | | | | | | | | | | |
| Temperature | $+125^{\circ}\text{C}$ | | $+85^{\circ}\text{C}$ | | | | | | | | | | | | | | | | | | | | | | | | | | | | | | | | | | | | |
| Time | 1000 hours | | | | | | | | | | | | | | | | | | | | | | | | | | | | | | | | | | | | | | |
| Voltage | 1.5x rated voltage applied | | | | | | | | | | | | | | | | | | | | | | | | | | | | | | | | | | | | | | |
| Recovery time | 24 ± 2 hours | | | | | | | | | | | | | | | | | | | | | | | | | | | | | | | | | | | | | | |
| 4 | Strength of Leads | Pull : > 4 kg | Fix the body of capacitor, apply a tensile weight gradually to each lead. | | | | | | | | | | | | | | | | | | | | | | | | | | | | | | | | | | | | |

Multilayer Ceramic Capacitor - Axial Ledged Type

TMA Series

Packing Information (Unit:mm)

Tape:

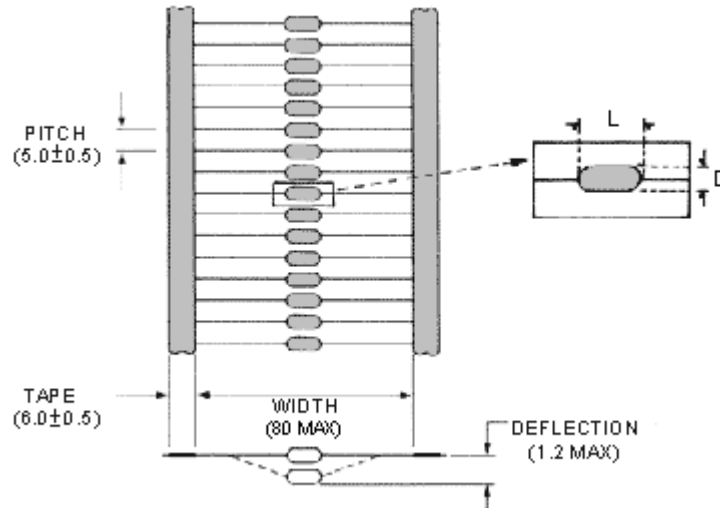

Reel:

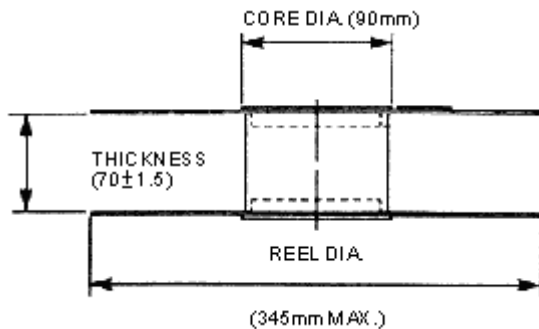

Ammo:

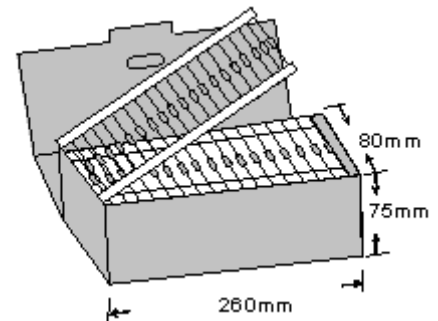

| Packing | Size Code | QTY |
|-------------|-----------|----------------|
| Tape & Reel | S | 7,500 pcs/Reel |
| | M | 7,500 pcs/Reel |
| Tape & Ammo | S | 5,000 pcs/Box |
| | M | 5,000 pcs/Box |

Multilayer Ceramic Capacitor - Axial Leded Type

TMA Series

How to order:

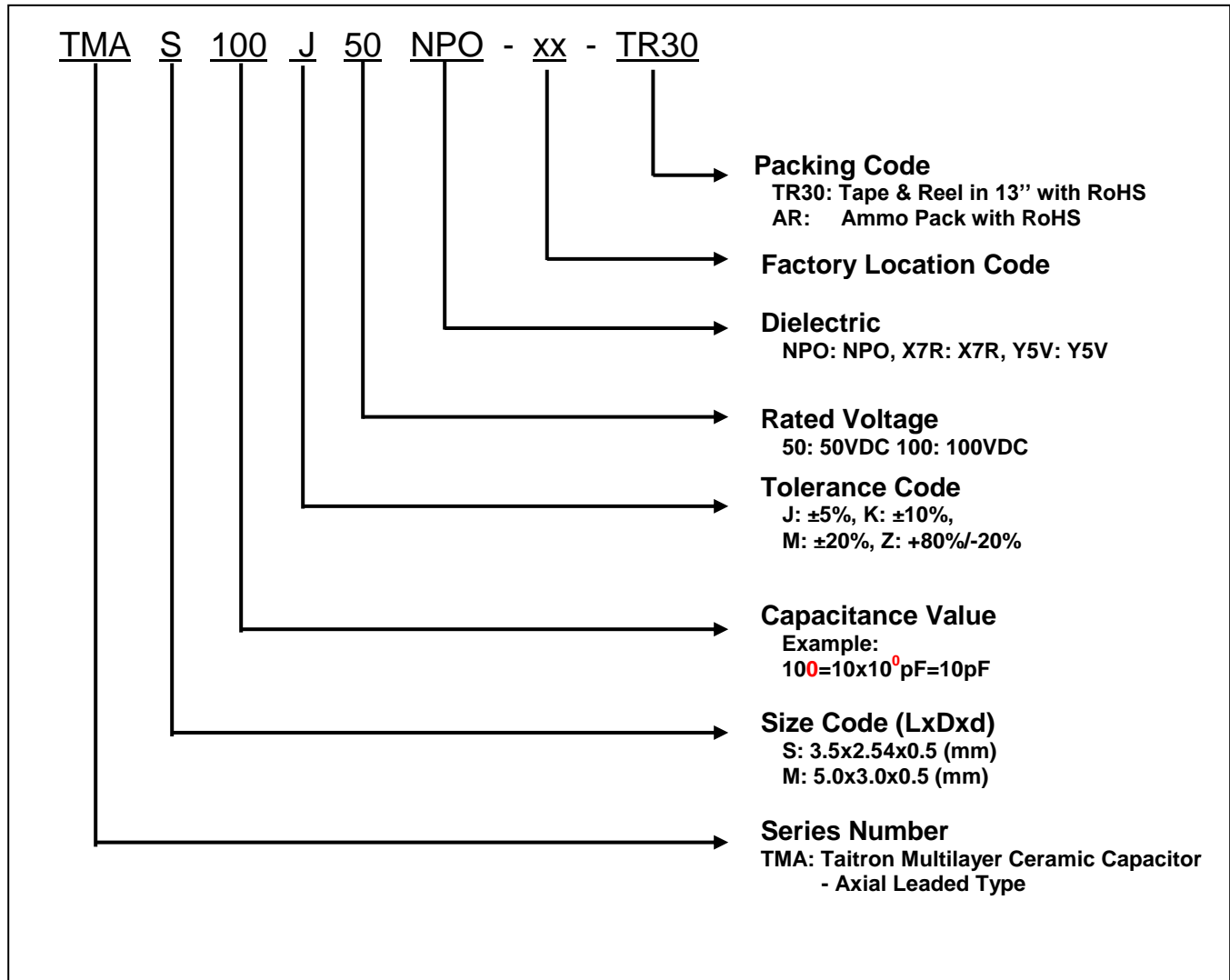

How to contact us

US HEADQUARTERS

28040 WEST HARRISON PARKWAY, VALENCIA, CA 91355-4162

Tel: (800)-TAITRON (800)-824-8766 (661)-257-6060

Fax: (800)-TAITFAX (800)-824-8329 (661)-257-6415

Email: taitron@taitroncomponents.com

Http://www.taitroncomponents.com

TAITRON COMPONENTS MEXICO, S.A .DE C.V.

BOULEVARD CENTRAL 5000 INTERIOR 5 PARQUE INDUSTRIAL ATITALAQUIA, HIDALGO
C.P. 42970 MEXICO

Tel: +52-55-5560-1519

Fax: +52-55-5560-2190

TAITRON COMPONENTS INCORPORATED TAIWAN, TAIPEI

6F., No.190, Sec. 2, Zhongxing Rd., Xindian Dist., New Taipei City 23146, Taiwan R.O.C.

Tel: 886-2-2913-6238

Fax: 886-2-2913-6239

TAITRON COMPONENT TECHNOLOGY, SHANGHAI CORPORATION

METROBANK PLAZA, 1160 WEST YAN'AN ROAD, SUITE 1503, SHANGHAI, 200052, CHINA

Tel: +86-21-5424-9942

Fax: +86-21-2302-5027