

### 3.0A Single-Phase Silicon Bridge Rectifier

#### Features

- High forward surge current capability
- Ideal for printed circuit board
- High temperature soldering guaranteed:  
260°C/10 seconds, at 5 lbs. (2.3kg) tension
- RoHS Compliant

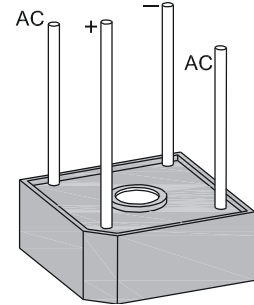

TB3



#### Mechanical Data

<b>Case:</b>	Molded plastic body
<b>Epoxy:</b>	Meets UL 94V-0 flammability rating
<b>Terminals:</b>	Lead solderable per MIL-STD-202E, Method 208C
<b>Polarity:</b>	Hole thru for #6 screw
<b>Weight:</b>	0.093 ounce, 2.62 grams

#### Maximum Ratings & Electrical Characteristics ( $T_{Ambient}=25^{\circ}C$ unless noted)

Symbol	Description	TB305	TB31	TB32	TB34	TB36	TB38	TB310	Unit	Conditions
<b>VRRM</b>	Maximum Repetitive Peak Reverse Voltage	50	100	200	400	600	800	1000	V	
<b>VRMS</b>	Maximum RMS Voltage	35	70	140	280	420	560	700	V	
<b>VDC</b>	Maximum DC Blocking Voltage	50	100	200	400	600	800	1000	V	
<b>IO(AV)</b>	Maximum Average Forward Rectified Current	3.0							A	TA=50°C
<b>IFSM</b>	Peak Forward Surge Current	50							A	Note
<b>VF</b>	Maximum Forward Voltage	1.1							V	IO=1.5A
<b>IR</b>	Maximum Reverse Current at Rated DC Blocking Voltage per element	5.0							uA	TA = 25 °C
		100								TA =100 °C
<b>TJ</b>	Operating Temperature Range	-55 to +125							°C	
<b>TSTG</b>	Storage Temperature Range	-55 to +150							°C	

#### Note:

1. 8.3 ms single half sine-wave superimposed on rated load (JEDEC Method)

# 3.0A Single-Phase Silicon Bridge Rectifier

TB305 - TB310

## Typical Characteristics Curves

Fig.1- Derating Curve for Output Rectified Current

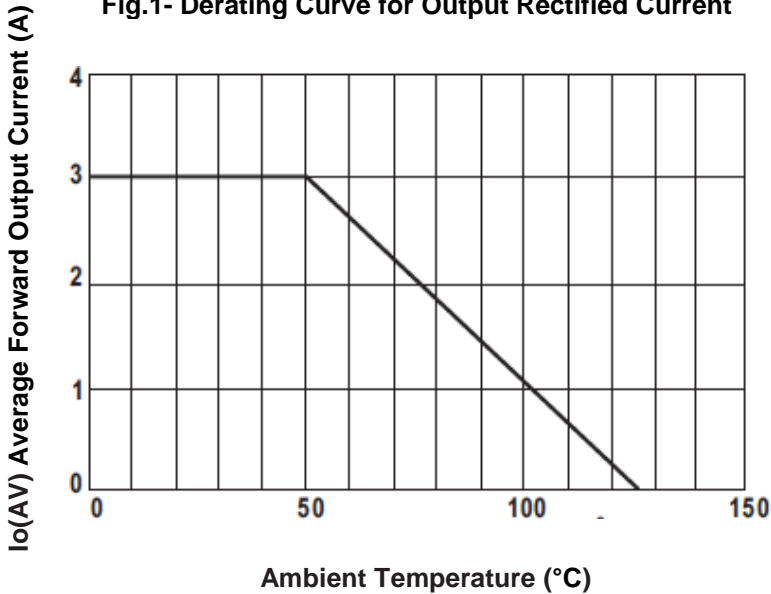

Fig.2- Maximum Non-Repetitive Peak Forward Surge Current Per Element

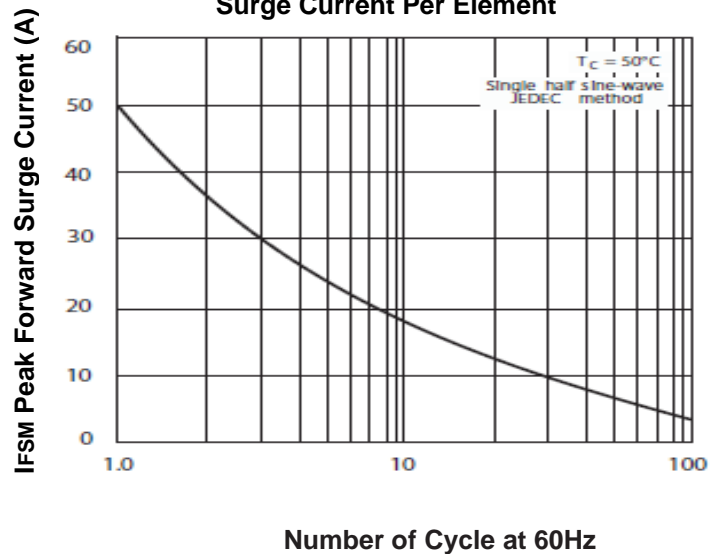

Fig.3- Typical Forward Characteristics Per Bridge Element

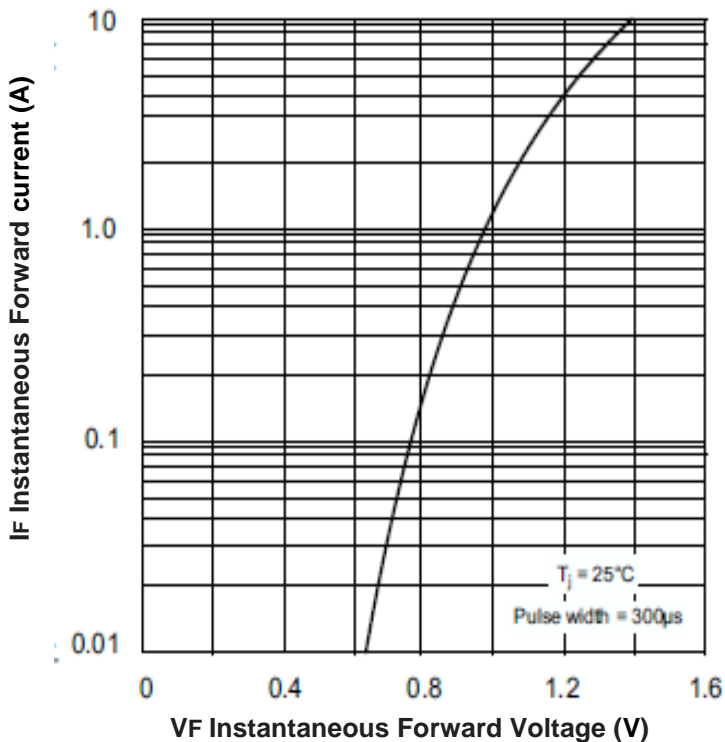
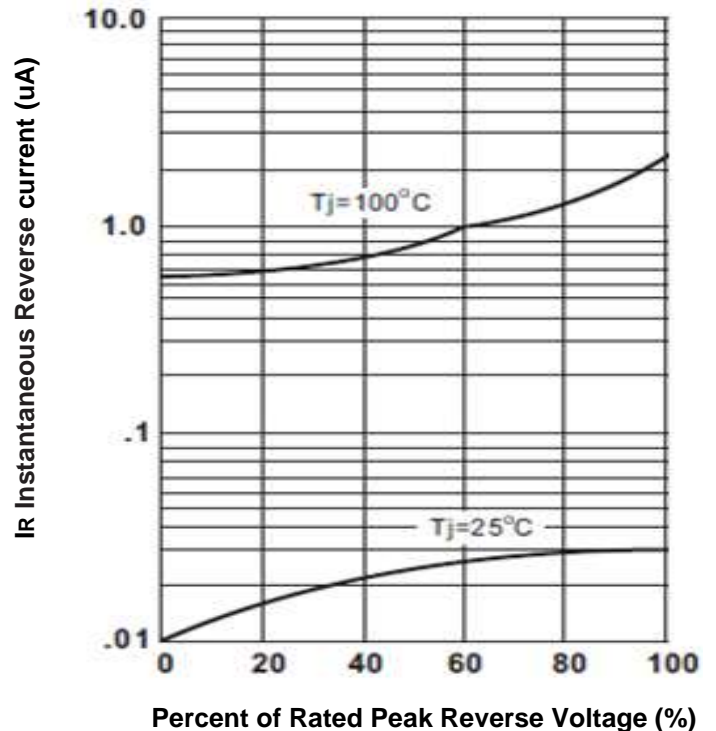

Fig.4- Typical Reverse Characteristics Per Bridge Element



# 3.0A Single-Phase Silicon Bridge Rectifier

TB305 - TB310

Dimensions in inch (mm)

TB3

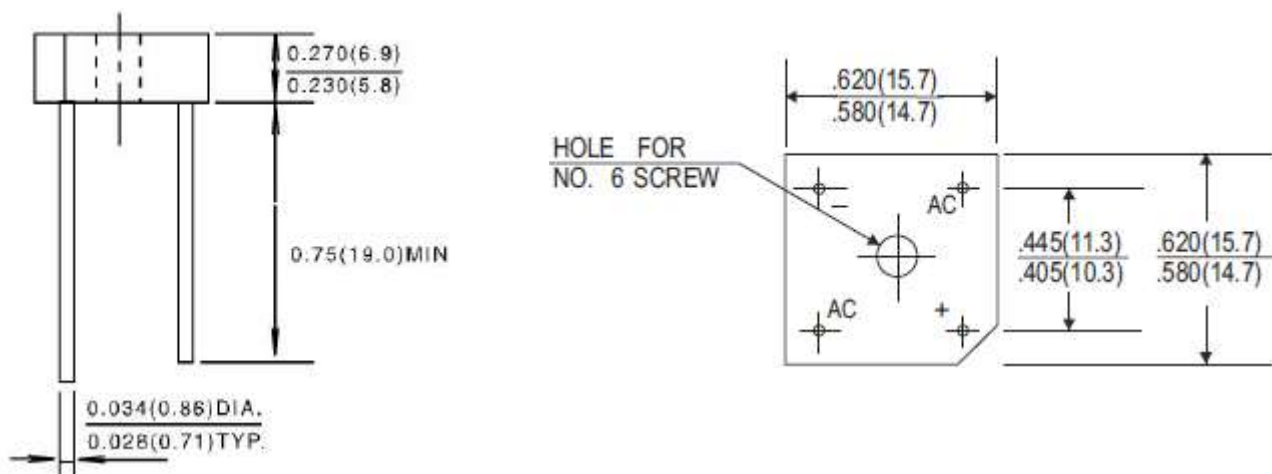

How to contact us

## USA HEADQUARTERS

28040 WEST HARRISON PARKWAY, VALENCIA, CA 91355-4162

Tel: (800)-TAITRON (800)-824-8766 (661)-257-6060

Fax: (800)-TAITFAX (800)-824-8329 (661)-257-6415

Email: [taitron@taitroncomponents.com](mailto:taitron@taitroncomponents.com)

Http://[www.taitroncomponents.com](http://www.taitroncomponents.com)

## TAITRON COMPONENTS INCORPORATED TAIWAN BRANCH

6F., NO.190, SEC. 2, ZHONGXING RD., XINDIAN DIST., NEW TAIPEI CITY 23146, TAIWAN R.O.C.

Tel: 886-2-2913-6238

Fax: 886-2-2913-6239

## TAITRON COMPONENT TECHNOLOG SHANGHAI CORPORATION

SUITE 1503, METROBANK PLAZA, 1160 WEST YAN'AN ROAD, SHANGHAI, 200052, CHINA

Tel: +86-21-5424-9942

Fax: +86-21-2302-5027