

200V/1.75A P-Channel Power MOSFET (Discontinued)

General Description

- Low on resistance
- Improved inductive ruggedness
- Fast switching time
- Rugged polysilicon gate cell structure
- Lower input capacitance
- Extended safe operating area
- Improved high temperature reliability

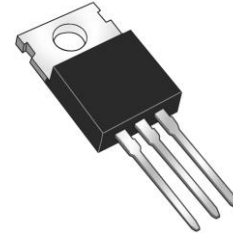

TO-220

Features

- $V_{DS} = -200V$, $I_D = -1.75A$
- $R_{DS(ON)} \leq 3.0 \Omega @ V_{GS} = -10V$

Pin Configuration

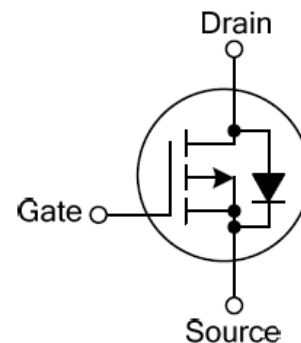
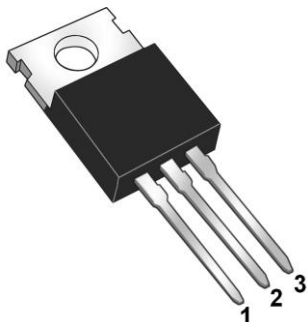

1: GATE 2: DRAIN 3: SOURCE

TO-220

Absolute Maximum Ratings

Symbol	Description	IRF9610	Unit
V_{DSS}	Drain-Source Voltage (1)	-200	Vdc
V_{DGR}	Drain-Gate Voltage ($R_{GS} = 1.0M\Omega$) (1)	-200	Vdc
V_{GS}	Gate-Source Voltage	± 20	Vdc
I_D	Drain Current –Continuous $T_c=25^\circ C$	-1.75	Adc
I_D	Drain Current –Continuous $T_c=100^\circ C$	-1.0	Adc
I_{DM}	Drain Current - Pulsed (2)	-7.0	Adc
I_{GM}	Gate Current - Pulsed	± 1.5	Adc
E_{AS}	Single Pulsed Avalanche Energy (3)	110	mJ
I_{AS}	Avalanche Current	-1.75	A
P_D	Total Power Dissipation $T_c=25^\circ C$ Derate above $25^\circ C$	20 0.16	W W/ $^\circ C$
T_J	Junction Temperature	+150	$^\circ C$
T_{STG}	Storage Temperature Range	-55 to +150	$^\circ C$
T_L	Maximum Lead Temp. for Soldering Purposes, 1/8" from case for 5 seconds	300	$^\circ C$

Note: (1) $T_J=25^\circ C$ to $150^\circ C$

(2) Repetitive rating: Pulse width limited by max. junction temperature

(3) $L=59mH$, $V_{dd}=-50V$, $R_G=25\Omega$, Starting $T_J=25^\circ C$

Electrical Characteristics ($T_c = 25^\circ C$ unless otherwise specified)

Off Characteristics

Symbol	Description	Min.	Typ.	Max.	Unit	Conditions
V_{(BR)DSS}	Drain-Source Breakdown Voltage	-200	-	-	V	$V_{GS}=0V$, $I_D=-250\mu A$
I_{DSS}	Zero Gate Voltage Drain Current	-	-	-250	uA	$V_{DS}=-Max.$ Rating, $V_{GS}=0V$
		-	-	-1000		$V_{DS}=-0.8$ Max. Rating, $V_{GS}=0V$, $T_c=125^\circ C$
I_{GSS}	Gate-Source Leakage Current	-	-	± 100	nA	$V_{GS}=\pm 20V$

On Characteristics

Symbol	Description	Min.	Typ.	Max.	Unit	Conditions
V_{GS(th)}	Gate Threshold Voltage	-2.0	-	-4.0	V	$V_{DS}=V_{GS}$, $I_D=-250\mu A$

Symbol	Description	Min.	Typ.	Max.	Unit	Conditions
R_{DS(ON)}	Static Drain-Source On-State Resistance (4)	-	-	3.0	Ω	V _{GS} =-10V, I _D =-0.9A
g_{FS}	Forward Transconductance (4)	0.7	-	-	S	V _{DS} ≤-50V, I _D =-0.9A

Note: (4) Pulse test: Pulse width ≤300us, Duty cycles≤2%

Dynamic Characteristics

Symbol	Description	Min.	Typ.	Max.	Unit	Conditions
C_{iss}	Input Capacitance	-	227	-	pF	V _{DS} =-25V, V _{GS} =0V, f=1MHz
C_{oss}	Output Capacitance	-	52.7	-		
C_{rss}	Reverse Transfer Capacitance	-	29.6	-		

Switching Characteristics

Symbol	Description	Min.	Typ.	Max.	Unit	Conditions
t_{D(on)}	Turn-On Delay Time	-	-	15	ns	V _{DD} =-0.5V _{DSS} , R _L =24Ω, I _D =-1.75A, (MOSFET switching times are essentially independent of operating temperature)
t_r	Turn-On Rise Time	-	-	25		
t_{D(off)}	Turn-Off Delay Time	-	-	15		
t_f	Turn-Off Fall Time	-	-	15		
Q_g	Total Gate Charge (Gate- Source Plus Gate-Drain)	-	-	18	nC	V _{GS} =-10V, I _D =-1.75A, V _{DS} =0.8 Max. Rating, (Gate charge is essentially independent of operating temperature)
Q_{gs}	Gate-Source Charge	-	2.6	-		
Q_{gd}	Gate-Drain Charge	-	7.6	-		

Drain-Source Diode Characteristics and Maximum Ratings

Symbol	Description	Min.	Typ.	Max.	Unit	Conditions
I_S	Continuous Source Current (Body Diode)	-	-	-1.75	A	Modified MOSFET symbol showing the integral reverse P-N junction rectifier-
I_{SM}	Pulse Source Current (Body Diode) (2)	-	-	-7.0	A	
V_{SD}	Diode Forward Voltage (4)	-	-	-5.8	V	I _S =-1.75A, V _{GS} =0V, T _J =25°C
T_{rr}	Reverse Recovery Time	-	240	-	ns	I _F =-1.75A, dI _F /dt=100A/μS, T _J =25°C

Note: (2) Repetitive rating: Pulse width limited by max. junction temperature

(4) Pulse test: Pulse width ≤300us, Duty cycles≤2%

Thermal Resistance

Symbol	Description	Typ.	Max.	Unit	Remark
$R_{\theta JC}$	Junction-to-Case	-	3.5	K/W	
$R_{\theta CS}$	Case-to-Sink	0.5	-	K/W	Mounting surface flat, smooth and greased
$R_{\theta JA}$	Junction-to-Ambient	-	62.5	K/W	Free air operation

Typical Characteristics Curves

Fig.1- Typical Output Characteristics

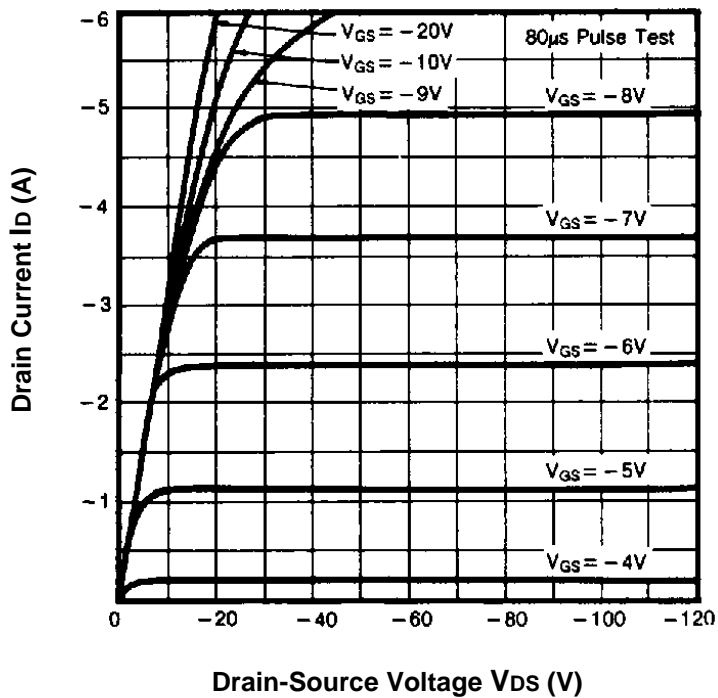

Fig.2- Typical Transfer Characteristics

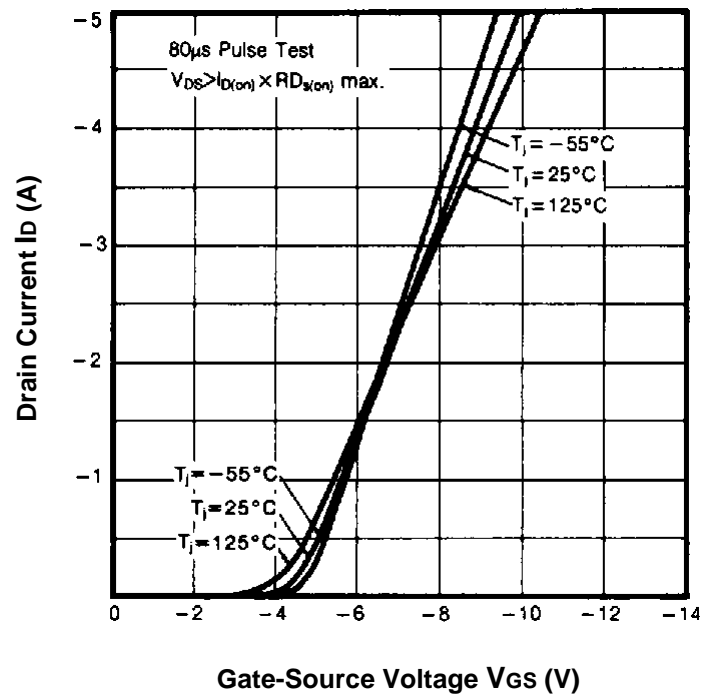

Fig.3- Typical Saturation Characteristics

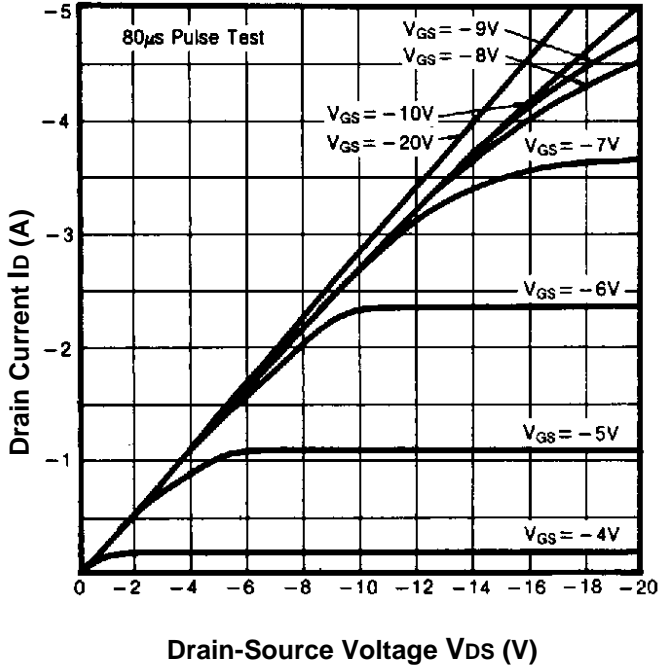

Fig.4- Maximum Safe Operation Area

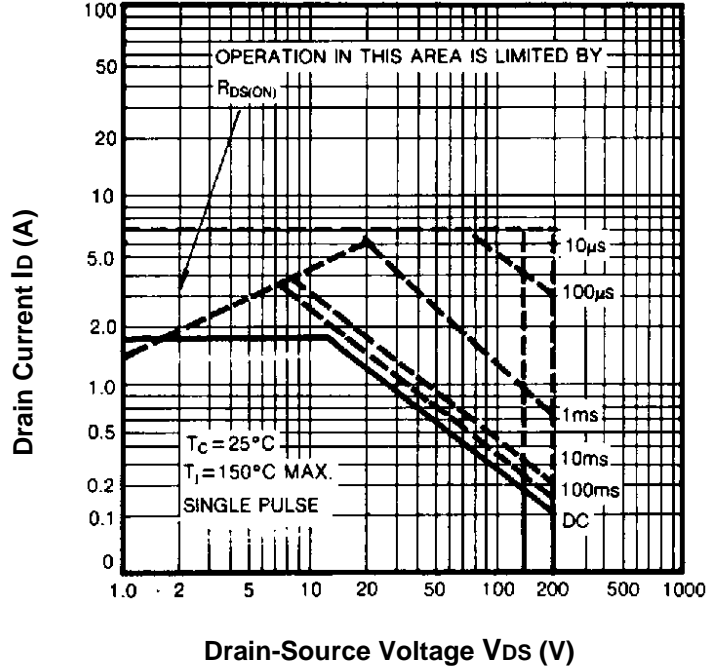

Fig.5- Maximum Effective Transient Thermal Response Junction-Case VS. Pulse Duration

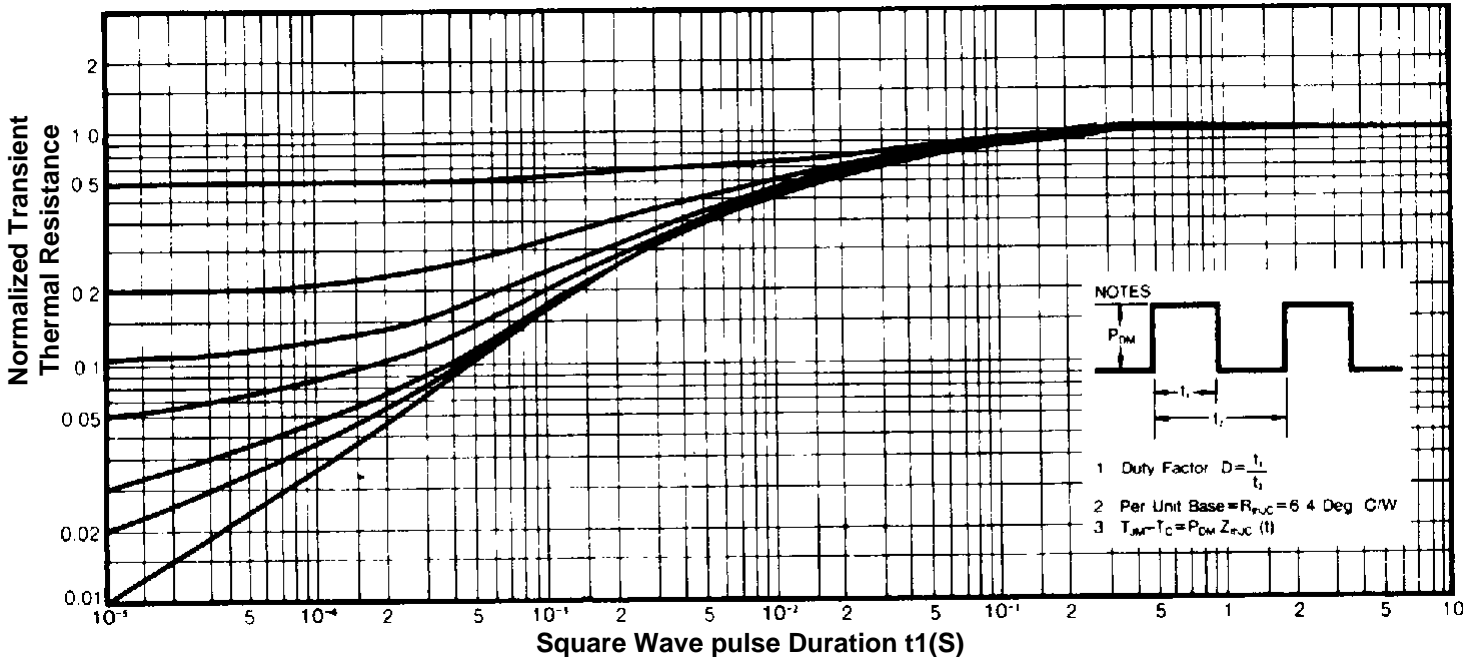

Fig.6- Typical Transconductance Vs. Drain Current

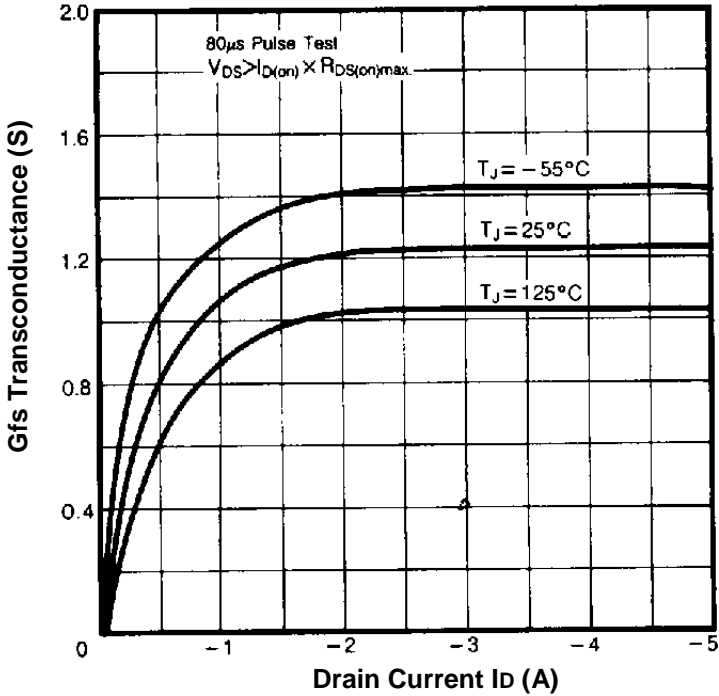

Fig.7- Typical Source-Drain Diode Forward Voltage

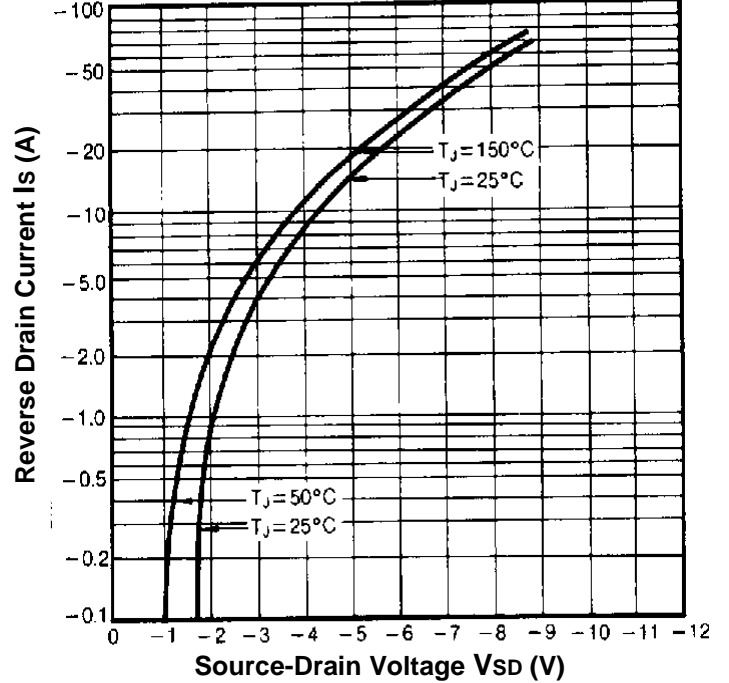

Fig.8- Breakdown Voltage Vs. Temperature

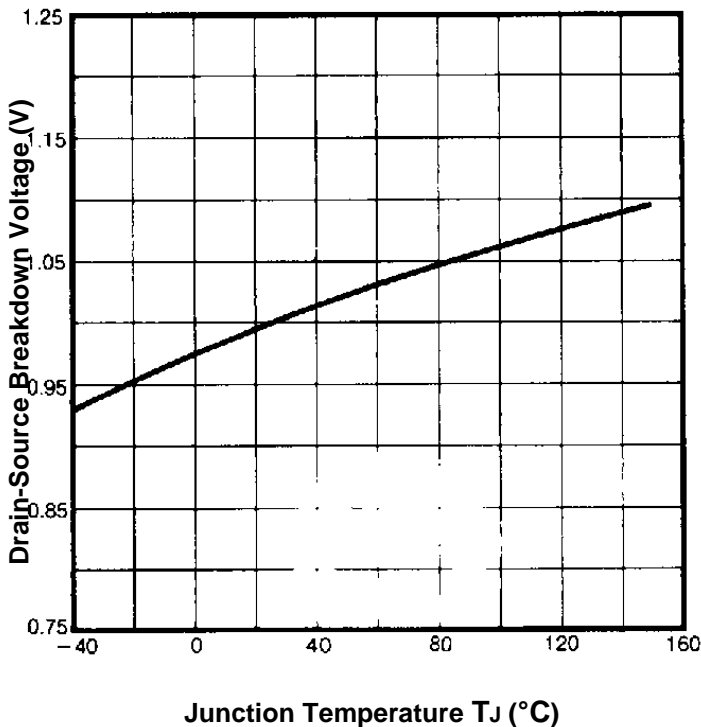

Fig.9- Normalized On-Resistance Vs. Temperature

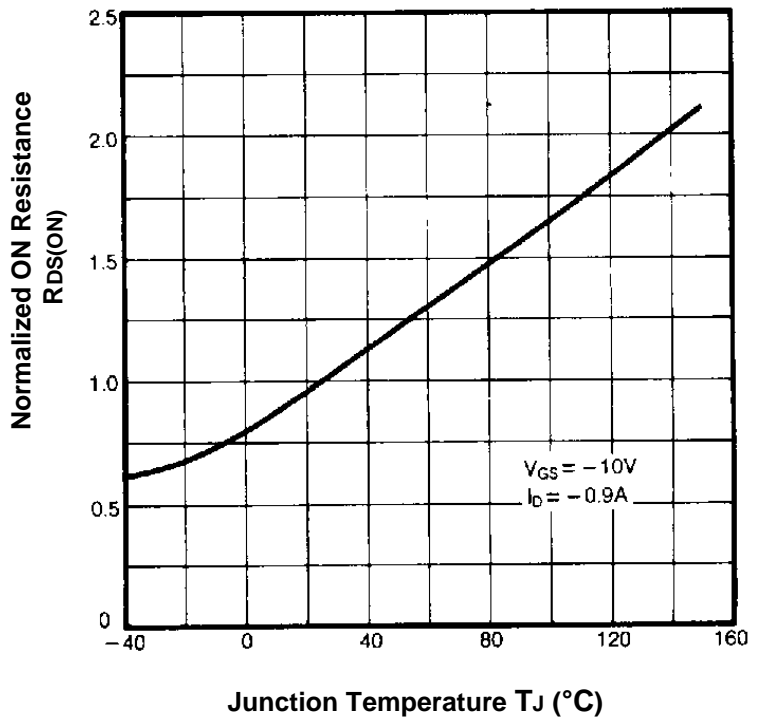

Fig.10- Typical Gate Charge Vs. Gate-Source Voltage

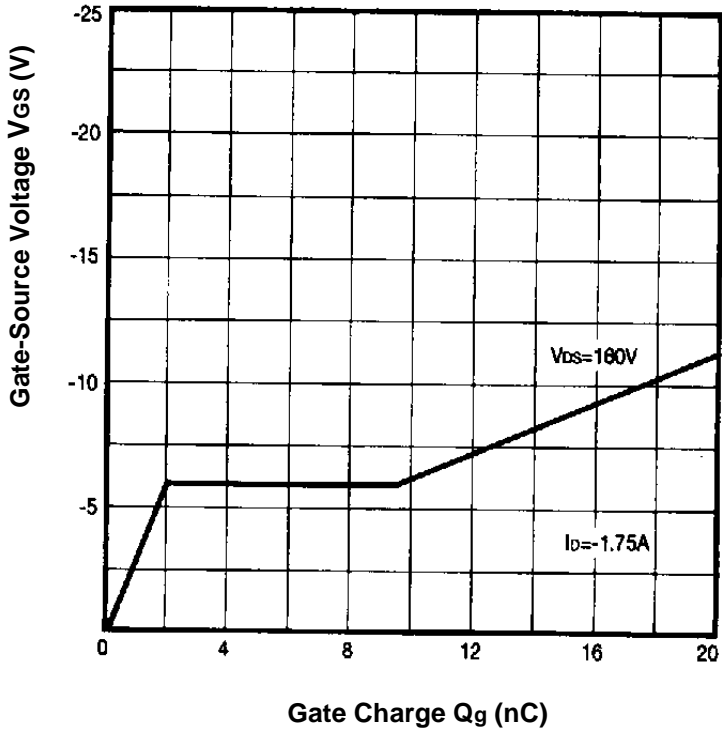

Fig.11- Typical Capacitance Vs. Drain-Source Voltage

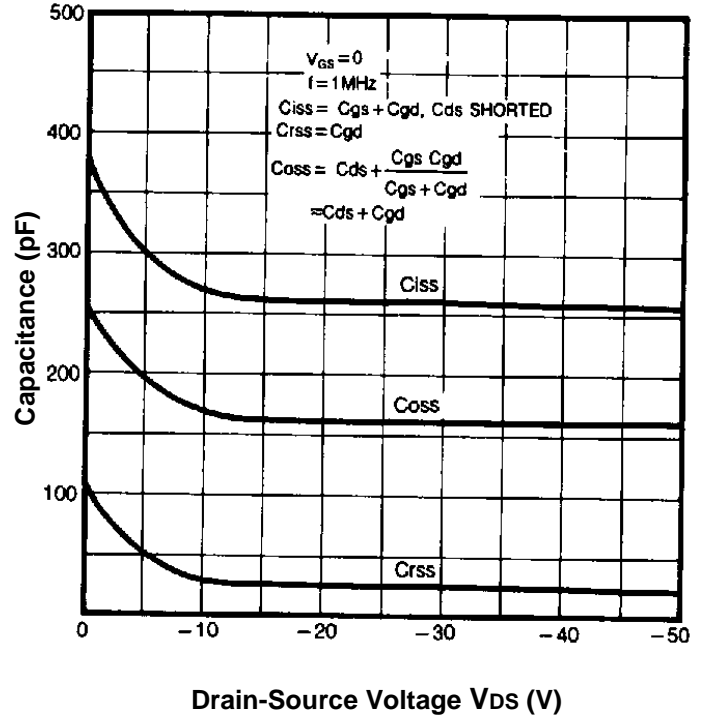

Fig.12- Typical On-Resistance Vs. Drain Current

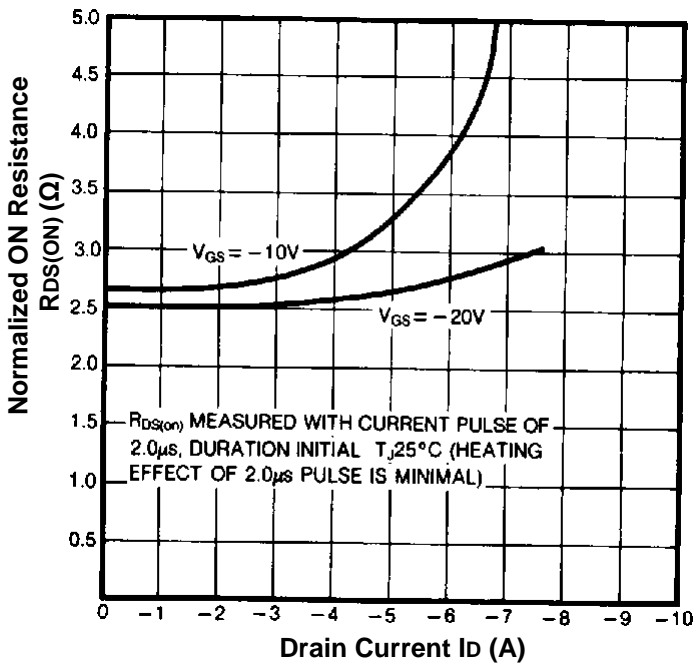

Fig.13- Maximum Drain Current Vs. Case Temperature

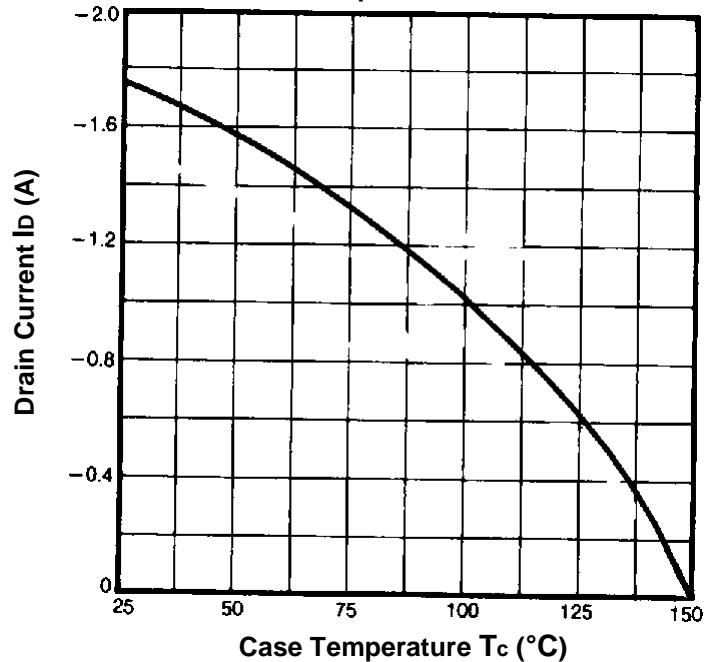
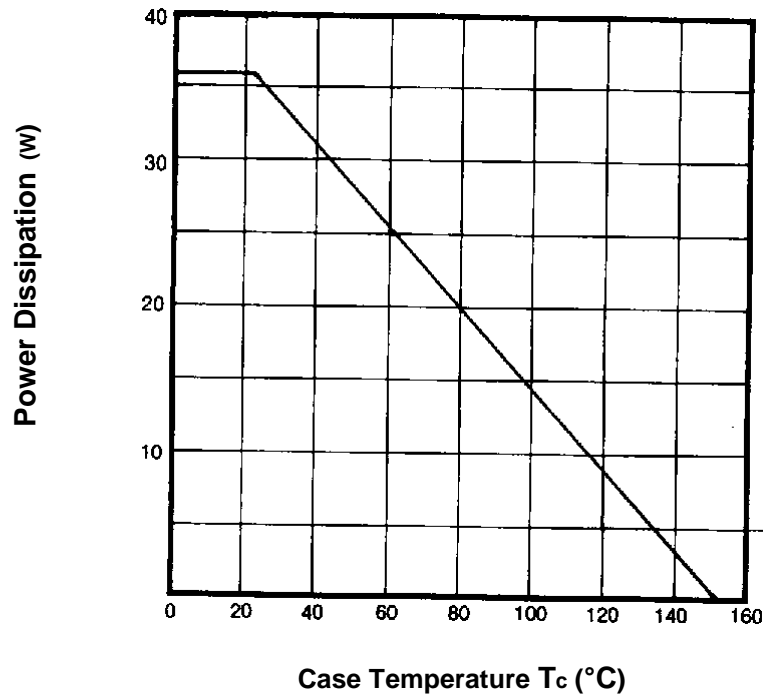
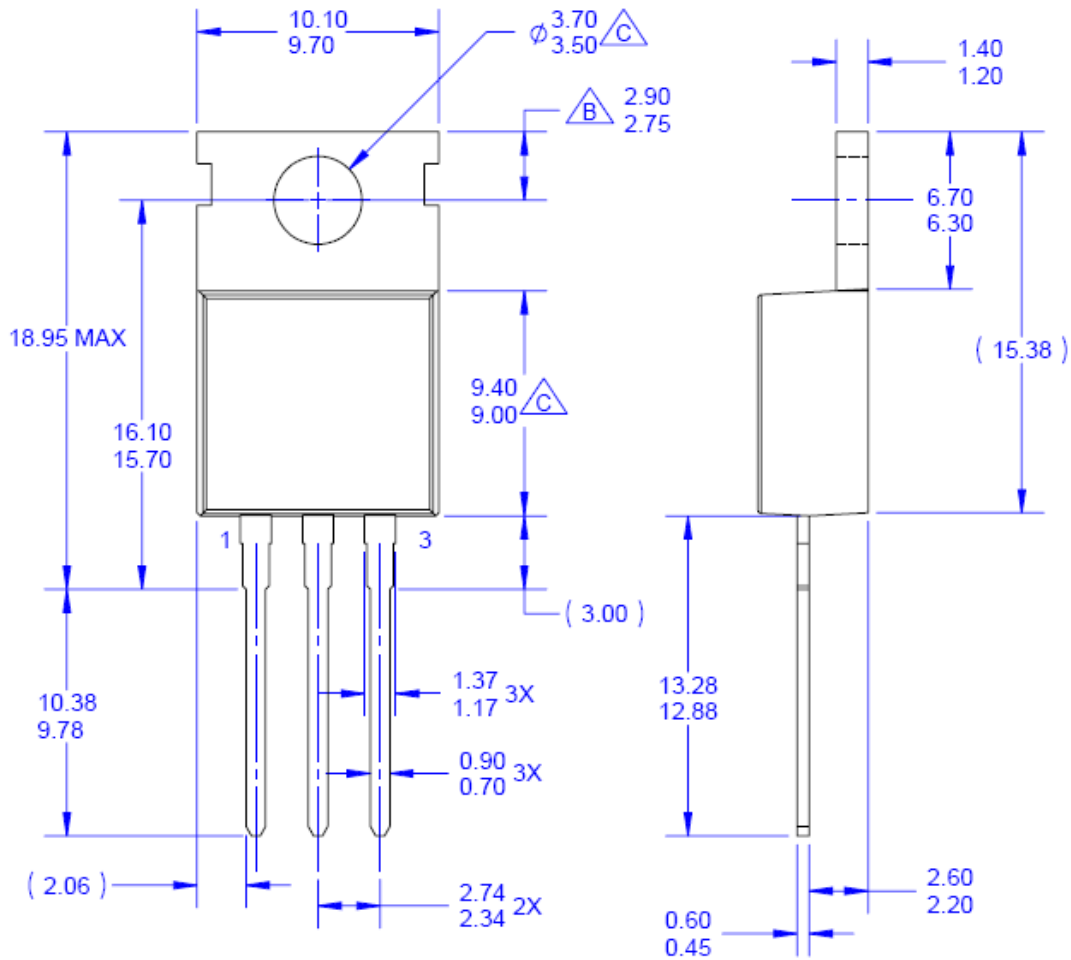

Fig.14-Power Vs. Temperature Derating Curve



Dimensions in mm



NOTES:

- A. PACKAGE CONFORMS TO JEDEC TO-220 VARIATION AB EXCEPT WHERE NOTED.
- B. ALL DIMENSIONS ARE IN MILLIMETERS.
- $\triangle C$ OUT OF JEDEC STANDARD VALUE.
- D. DIMENSIONS ARE EXCLUSIVE OF BURRS, MOLD FLASH AND TIE BAR PROTRUSIONS.

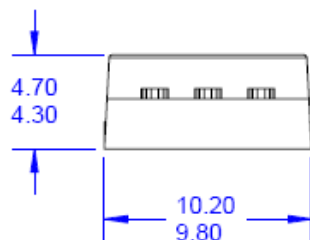

TO-220

Order Information

Part # to order	Manufacturer	Outline	Packing	RoHS Status
IRF9610-SM-C	SAMSUNG	TO-220	Tube	NO

How to contact us**USA HEADQUARTERS**

28040 WEST HARRISON PARKWAY, VALENCIA, CA 91355-4162

Tel: (800)-TAITRON (800)-824-8766 (661)-257-6060

Fax: (800)-TAITFAX (800)-824-8329 (661)-257-6415

Email: taitron@taitroncomponents.comHttp://www.taitroncomponents.com**TAITRON COMPONENTS INCORPORATED TAIWAN BRANCH**

6F., NO.190, SEC. 2, ZHONGXING RD., XINDIAN DIST., NEW TAIPEI CITY 23146, TAIWAN R.O.C.

Tel: 886-2-2913-6238

Fax: 886-2-2913-6239

TAITRON COMPONENT TECHNOLOG SHANGHAI CORPORATION

SUITE 1503, METROBANK PLAZA, 1160 WEST YAN'AN ROAD, SHANGHAI, 200052, CHINA

Tel: +86-21-5424-9942

Fax: +86-21-2302-5027