

## 20KW Transient Voltage Suppressor

### Features

- Glass passivated junction
- 20KW peak pulse power capability at 10/1000µs waveform repetition rate (duty cycles): 0.01%
- Fast response time: typically less than 1.0ps from 0v to VBR min.
- Excellent clamping capability
- Low incremental surge resistance
- High temperature soldering guaranteed:  
260°C/40 seconds, 0.375" (9.5mm) lead length at 5lbs. (2.3kg) tension
- 20KPA series is UL recognized under component index. File number E315008
- RoHS Compliant and Halogen free.



T6L



**HALOGEN FREE**

### Mechanical Data

<b>Case:</b>	T6L molded plastic body over passivated junction
<b>Epoxy:</b>	Plastic package has UL flammability classification 94V-0
<b>Lead:</b>	Plated axial leads, solderable per MIL-STD-750, Method 2026
<b>Polarity:</b>	Color band denotes the cathode except Bi-directional
<b>Mounting position:</b>	Any
<b>Weight:</b>	0.07 ounce, 2.5 grams

### Maximum Ratings ( $T_{Ambient}=25^{\circ}C$ unless noted otherwise)

Symbol	Description	Value	Unit	Conditions
<b>V<sub>WM</sub></b>	Maximum Recurrent Peak Reverse Voltage	20 to 300	V	
<b>P<sub>PPM</sub></b>	Peak Pulse Power Dissipation on 10/1000µs Waveform	20	KW	Note 1
<b>P<sub>D</sub></b>	Steady State Power Dissipation on infinite heat sink at $T_L=75^{\circ}C$	8.0	W	
<b>I<sub>FSM</sub></b>	Peak Forward Surge Current, Uni-directional only	400	A	8.3ms single half sine-wave or equivalent square wave, duty cycle=4 pulses per minute maximum
<b>R<sub>thJA</sub></b>	Typical Thermal Resistance to Ambient	40	$^{\circ}C/W$	
<b>R<sub>thJL</sub></b>	Typical Thermal Resistance to Lead	8.0	$^{\circ}C/W$	
<b>T<sub>J</sub>, T<sub>STG</sub></b>	Operating Junction and Storage Temperature Range	-55 to +175	$^{\circ}C$	

**Notes:** (1) Non-repetitive current pulse, per Fig.3 and derated above  $T_A = 25^{\circ}C$  per Fig. 2

# 20KW Transient Voltage Suppressor

## 20KPA20A - 20KPA300CA

### Electrical Characteristics ( $T_{Ambient}=25^{\circ}C$ unless noted otherwise)

P/N (note3)		Stand-Off Voltage	Breakdown Voltage @ Test Current (note1)		Max. Reverse Leakage Current @ $V_{WM}$	Max. Clamping Voltage @ IPPM	Max. Peak Pulse Current
			$V_{BR}$	$I_T$ (mA)			
Uni-Polar	Bi-Polar	$V_{WM}$ (V)	Min.		$I_D$ ( $\mu A$ ) (note2)	$V_C$ (V)	IPPM (A) (note1)
20KPA20A	20KPA20CA	20	22.34	50	5000	36.8	548.9
20KPA24A	20KPA24CA	24	26.81	50	5000	41.2	490.3
20KPA26A	20KPA26CA	26	29.04	50	2000	44.7	451.9
20KPA28A	20KPA28CA	28	31.28	50	1000	48.0	420.8
20KPA30A	20KPA30CA	30	33.51	5	250	51.5	392.2
20KPA32A	20KPA32CA	32	35.74	5	150	54.3	372.0
20KPA34A	20KPA34CA	34	38.00	5	50	57.5	351.3
20KPA36A	20KPA36CA	36	40.20	5	20	61.5	328.5
20KPA40A	20KPA40CA	40	44.70	5	15	67.8	297.9
20KPA44A	20KPA44CA	44	49.10	5	2	72.7	277.9
20KPA48A	20KPA48CA	48	53.60	5	2	79.4	254.4
20KPA52A	20KPA52CA	52	58.10	5	2	85.8	235.4
20KPA56A	20KPA56CA	56	62.60	5	2	92.6	218.1
20KPA60A	20KPA60CA	60	67.00	5	2	97.6	207.0
20KPA64A	20KPA64CA	64	71.50	5	2	104.0	194.2
20KPA68A	20KPA68CA	68	76.00	5	2	110.0	183.6
20KPA72A	20KPA72CA	72	80.40	5	2	116.0	174.1
20KPA80A	20KPA80CA	80	89.40	5	2	130.0	155.4
20KPA88A	20KPA88CA	88	98.30	5	2	142.0	142.3
20KPA96A	20KPA96CA	96	107.20	5	2	155.0	130.3
20KPA104A	20KPA104CA	104	116.20	5	2	168.0	120.2
20KPA112A	20KPA112CA	112	125.10	5	2	182.0	111.0
20KPA120A	20KPA120CA	120	134.00	5	2	194.0	104.1
20KPA132A	20KPA132CA	132	147.40	5	2	213.0	94.8

# 20KW Transient Voltage Suppressor

## 20KPA20A - 20KPA300CA

P/N (note3)		Stand-Off Voltage	Breakdown Voltage @ Test Current (note1)		Max. Reverse Leakage Current @ V <sub>WM</sub>	Max. Clamping Voltage @ I <sub>PPM</sub>	Max. Peak Pulse Current
			V <sub>BR</sub>	I <sub>T</sub> (mA)			
Uni-Polar	Bi-Polar	V <sub>WM</sub> (V)	Min.		I <sub>D</sub> (μA) (note2)	V <sub>C</sub> (V)	I <sub>PPM</sub> (A) (note1)
20KPA144A	20KPA144CA	144	160.80	5	2	232.0	87.1
20KPA160A	20KPA160CA	160	178.70	5	2	258.0	78.3
20KPA172A	20KPA172CA	172	192.10	5	2	277.0	72.9
20KPA180A	20KPA180CA	180	201.10	5	2	291.0	69.4
20KPA192A	20KPA192CA	192	214.50	5	2	309.0	65.4
20KPA204A	20KPA204CA	204	227.90	5	2	329.0	61.4
20KPA216A	20KPA216CA	216	241.30	5	2	348.0	58.0
20KPA232A	20KPA232CA	232	259.10	5	2	374.0	54.0
20KPA240A	20KPA240CA	240	268.10	5	2	387.0	52.2
20KPA256A	20KPA256CA	256	286.00	5	2	412.0	49.0
20KPA280A	20KPA280CA	280	312.80	5	2	451.0	44.8
20KPA300A	20KPA300CA	300	335.10	5	2	483.0	41.8

- Note:**
1. Surge current waveform per Fig. 3 and derate per Fig. 2.
  2. For Bi-directional types with V<sub>WM</sub> of 10 volts and less, the I<sub>D</sub> limit is doubled.
  3. C suffix for Bidirectional use, A suffix for 5% tolerance.

# 20KW Transient Voltage Suppressor

## 20KPA20A - 20KPA300CA

### Typical Characteristics Curves

Fig.1- Peak Pulse Power Rating Curve

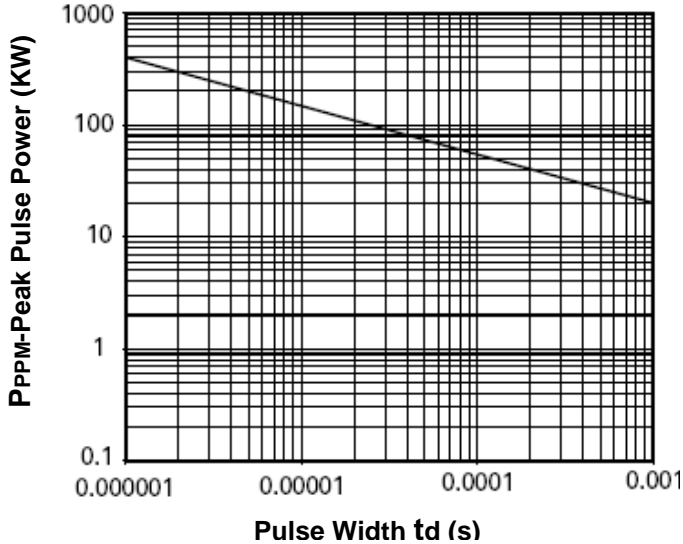

Fig.2- Pulse Derating Curve

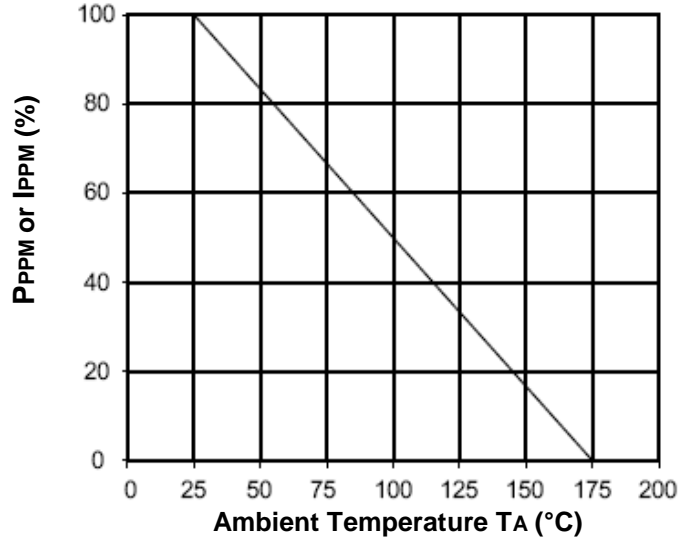

Fig.3- Pulse Waveform

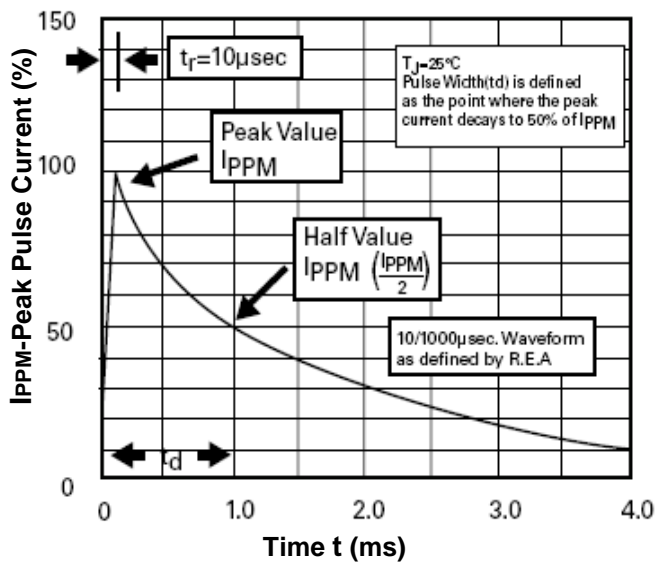
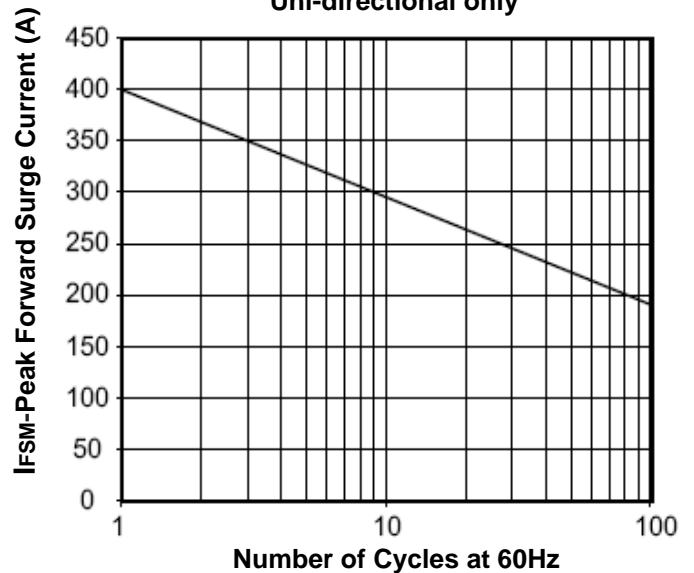

Fig.4- Max. Non-Repetitive Forward Surge Current Uni-directional only



# 20KW Transient Voltage Suppressor

## 20KPA20A - 20KPA300CA

Fig.5- Steady State Power Derating Curve

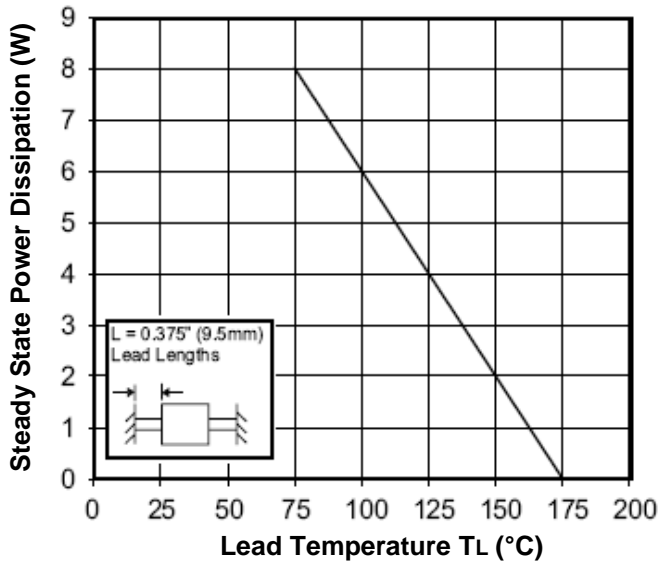
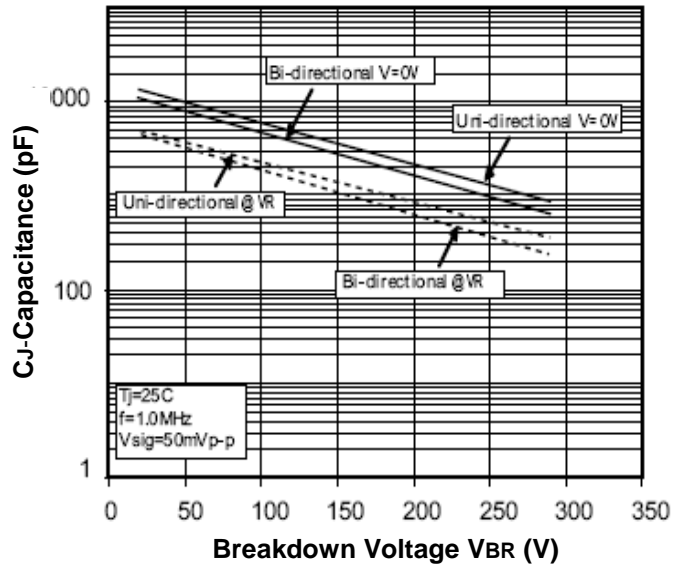
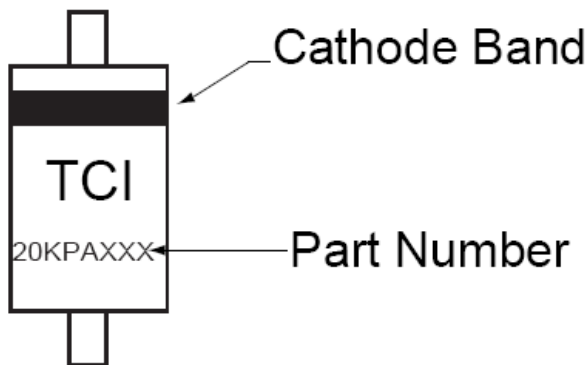

Fig.6- Typical Junction Capacitance



### Marking Information

Uni-directional



Bi-directional

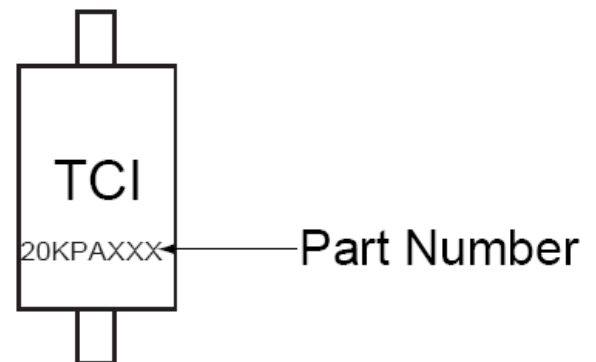

# 20KW Transient Voltage Suppressor

## 20KPA20A - 20KPA300CA

Dimensions in inch (mm)

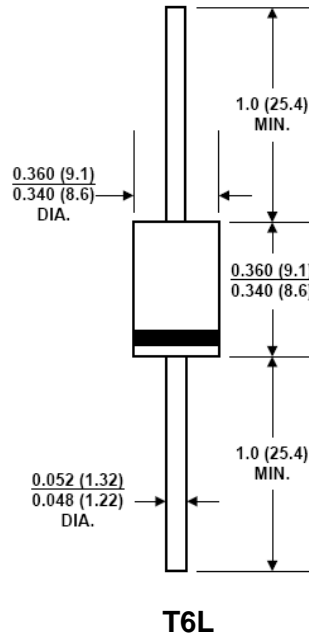

How to contact us:

### USA HEADQUARTERS

28040 WEST HARRISON PARKWAY, VALENCIA, CA 91355-4162

Tel: (800)-TAITRON (800)-824-8766 (661)-257-6060

Fax: (800)-TAITFAX (800)-824-8329 (661)-257-6415

Email: [taitron@taitroncomponents.com](mailto:taitron@taitroncomponents.com)

Http://[www.taitroncomponents.com](http://www.taitroncomponents.com)

### TAITRON COMPONENTS INCORPORATED TAIWAN BRANCH

6F., NO.190, SEC. 2, ZHONGXING RD., XINDIAN DIST., NEW TAIPEI CITY 23146, TAIWAN R.O.C.

Tel: 886-2-2913-6238

Fax: 886-2-2913-6239

### TAITRON COMPONENT TECHNOLOG SHANGHAI CORPORATION

SUITE 1503, METROBANK PLAZA, 1160 WEST YAN'AN ROAD, SHANGHAI, 200052, CHINA

Tel: +86-21-5424-9942

Fax: +86-21-2302-5027