

Switching Diodes

Features

- Fast Switching Speed
- High Conductance
- Electrically Identical to Standard JEDEC
- RoHS compliant

Mechanical Data

Case:	DO-35, Molded Glass
Terminals:	Axial leads, solderable per MIL-STD-202, Method 208
Weight:	0.13 gram

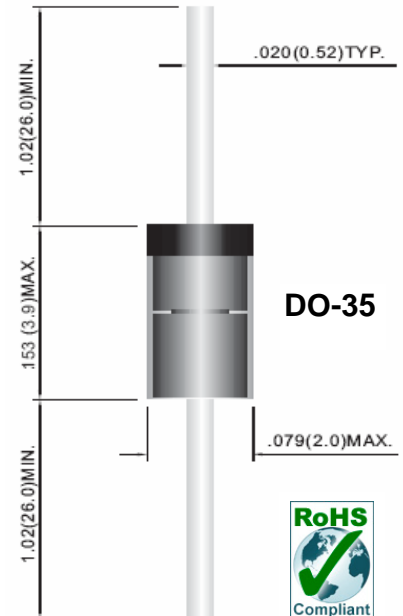

Maximum Ratings *(T_{Ambient}=25°C unless noted otherwise)*

Symbol	Description	1N4148	1N4448	Unit	Conditions
V_{RM}	Reverse Voltage	75		V	
V_{RRM}	Peak Reverse Voltage	100		V	
I_{F(AV)}	Forward Average Current	150		mA	Valid provided that leads at a distance of 8mm from case are kept at ambient temperature
I_{FSM}	Peak Forward Surge Current, Pulse Width=1.0us	2.0		A	
P_D	Power Dissipation above 25°C	500		mW	
V_F	Forward Voltage	Min	---	0.62 @ 5mA	V
		Max	1.0 @ 10mA	0.72 @ 5mA 1.0 @ 100mA	
I_R	Max. Reverse Current	0.025	0.025	μA	VR=20V
		5.0	5.0		VR=75V
C_D	Diode Capacitance	4.0		pF	VR=0V, f=1MHz
T_{rr}	Reverse Recovery Time	4.0		ns	IF= 10mA, IR=1mA, VR=6V, RL=100Ω
T_J, T_{STG}	Operating Junction and Storage Temperature Range	-65 to +175		°C	

Typical Characteristics Curves

Fig.1- Power Derating Curve

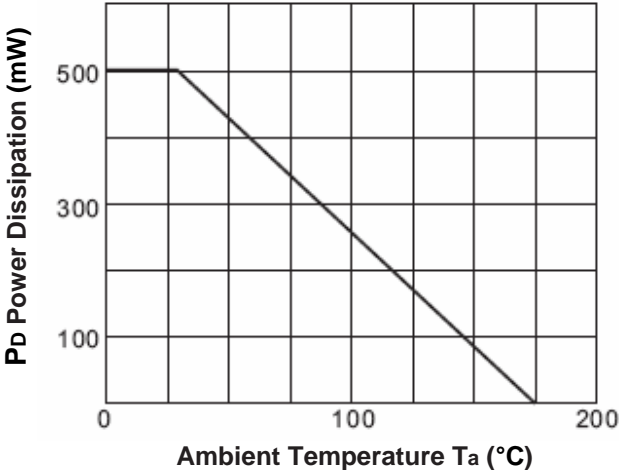

Fig.2- Typical Forward Characteristics

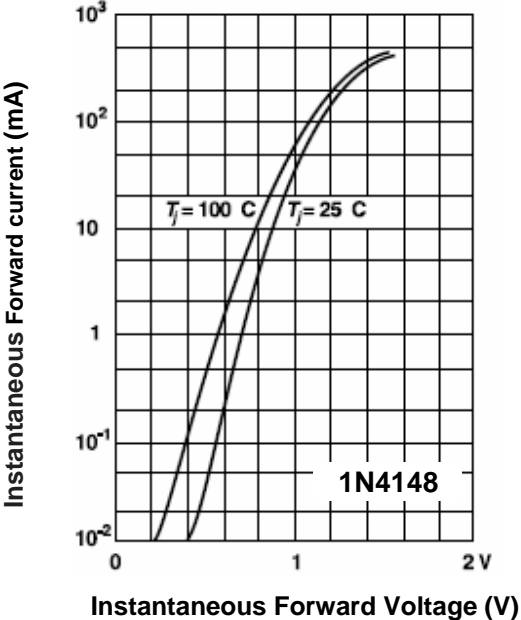

Fig.2- Typical Forward Characteristics

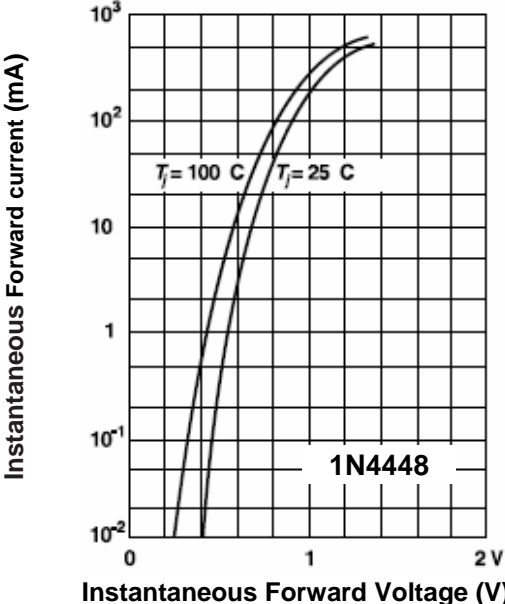
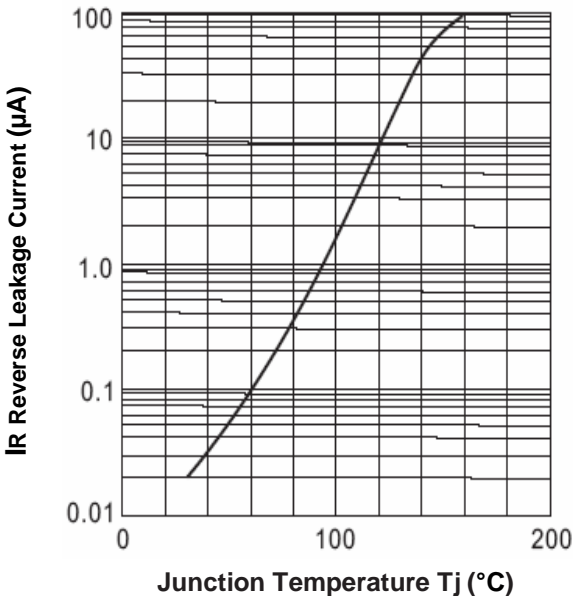
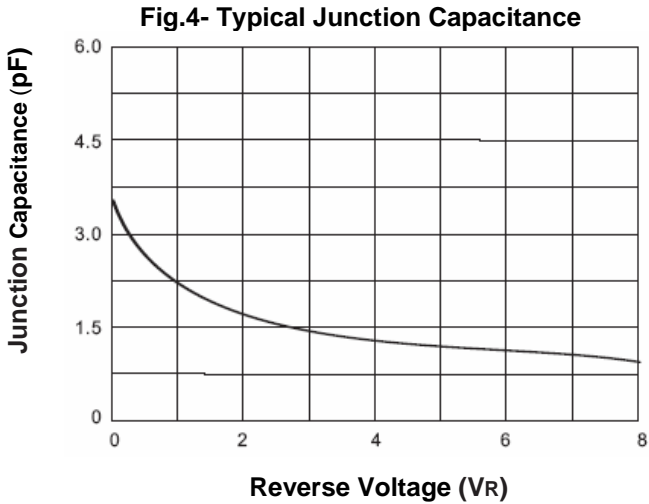
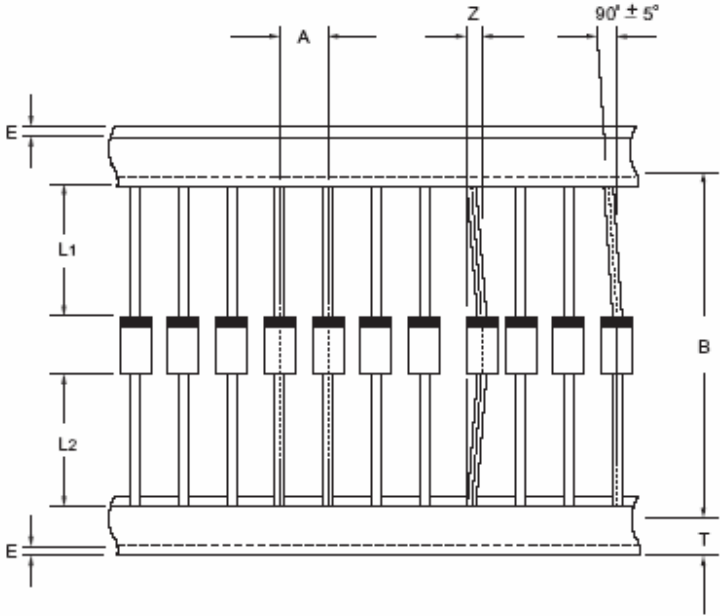

Fig.3- Leakage Current VS Junction Temperature





Taping Information (in mm)



Components Outline	A	B	L1,L2	T	E	Z
DO-35	5±0.5	52±1	Max.1.0	6±0.4	Max.0.8	Max.1.2

How to contact us:

US HEADQUARTERS

28040 WEST HARRISON PARKWAY, VALENCIA, CA 91355-4162

Tel: (800) TAITRON (800) 247-2232 (661) 257-6060

Fax: (800) TAITFAX (800) 824-8329 (661) 257-6415

Email: taitron@taitroncomponents.com

Http://www.taitroncomponents.com

TAITRON COMPONENTS MEXICO, S.A .DE C.V.

BOULEVARD CENTRAL 5000 INTERIOR 5 PARQUE INDUSTRIAL ATITALAQUIA, HIDALGO C.P.
42970 MEXICO

Tel: +52-55-5560-1519

Fax: +52-55-5560-2190

TAITRON COMPONENTS INCORPORATED REPRESENTAÇÕES DO BRASIL LTDA

RUA DOMINGOS DE MORAIS, 2777, 2.ANDAR, SALA 24 SAÚDE - SÃO PAULO-SP 04035-001 BRAZIL

Tel: +55-11-5574-7949

Fax: +55-11-5572-0052

TAITRON COMPONENTS INCORPORATED, SHANGHAI REPRESENTATIVE OFFICE

CROSS REGION PLAZA, 899 LINGLING ROAD, SUITE 18C, SHANGHAI, 200030, CHINA

Tel: +86-21-5424-9942

Fax: +86-21-5424-9931