

### 1500W Transient Voltage Suppressor

#### Features

- Glass passivated junction
- 1500W Peak Pulse Power capability on 10/1000µs waveform repetition rate(duty cycle): 0.05%
- Fast response time: typically less than 1.0ps from 0v to VBR for uni-direction and 5.0ns for bi-direction types
- Low incremental surge resistance, excellent clamping capability
- High temperature soldering guaranteed:  
265°C/10 seconds, 0.375" (9.5mm) lead length at 5lbs. (2.3kg tension)
- 1.5KE6.8A/CA -1.5KE550A/CA is UL recognized under component index. File number E315008

1.5KE

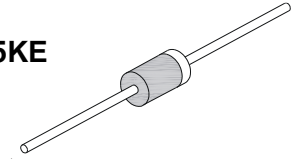

#### Mechanical Data

<b>Case:</b>	Molded plastic black body, 1.5KE
<b>Lead:</b>	Plated axial leads, solderable per MIL-STD-750, Method 2026
<b>Polarity:</b>	Color band denoted positive end (cathode) except for Bi-directional
<b>Mounting position:</b>	Any
<b>Weight:</b>	0.045 ounce, 1.2 grams

#### Maximum Ratings ( $T_{Ambient}=25^{\circ}C$ unless noted otherwise)

Symbol	Description	Value	Unit	Conditions
<b>VWM</b>	Maximum Recurrent Peak Reverse Voltage	6.8 to 600	V	
<b>PPPM</b>	Peak Pulse Power Dissipation on 10/1000µs waveform	1500	W	Note 1
<b>IPPM</b>	Peak Pulse Current with a 10/1000µs waveform	See Next Table	A	Note 1
<b>P<sub>M(AV)</sub></b>	Steady State Power Dissipation at $T_L=75^{\circ}C$ , Lead Lengths 0.375", (9.5mm)	6.5	W	Note 2
<b>IFSM</b>	Peak Forward Surge Current, Uni-directional only (2)	200	A	Note 3
<b>V<sub>F</sub></b>	Maximum Instantaneous Forward Voltage at 100A for Uni-directional only	3.5	V	1.5KE6.8~1.5KE200 1N6267~1N6303
		5.0		1.5KE220~1.5KE600

# 1500W Transient Voltage Suppressor

## 1.5KE6.8A - 1.5KE600CA/1N6267A -1N6303CA

Symbol	Description	Value	Unit	Conditions
R <sub>thJA</sub>	Typical Thermal Resistance Junction to Ambient	75	° C/W	
R <sub>thJL</sub>	Typical Thermal Resistance Junction to Lead	20	° C/W	
T <sub>J</sub> ,T <sub>STG</sub>	Operating Junction and Storage Temperature Range	-55 to 175	° C	

- Notes:** (1) Non-repetitive current pulse, per Fig.3 and derated above T<sub>A</sub> = 25°C per Fig. 2  
 (2) Mounted on copper pad area of 1.6×1.6" (40×40mm) per Fig. 5.  
 (3) 8.3ms single half sine-wave, or equivalent square wave, Duty cycle=4 pulses per minutes max.

### Electrical Characteristics (T<sub>Ambient</sub>=25°C unless noted otherwise)

P/N				Stand-Off Voltage	Breakdown Voltage @ Test Current (note1)			Max. Reverse Leakage Current @ V <sub>WM</sub>	Max. Clamping Voltage @ I <sub>PPM</sub>	Max. Peak Pulse Current	Max. Temperature Coefficient of V <sub>BR</sub> (%/° C)
Uni-Polar	Bi-Polar	Uni-Polar	Bi-Polar		V <sub>BR</sub>		I <sub>T</sub> (mA)				
				V <sub>WM</sub> (V)	Min.	Max.		I <sub>D</sub> (μA)	V <sub>C</sub> (V)	I <sub>PPM</sub> (A)	
1N6267A	1N6267CA	1.5KE6.8A	1.5KE6.8CA	5.8	6.45	7.14	10	1000	10.5	144.8	0.057
1N6268A	1N6268CA	1.5KE7.5A	1.5KE7.5CA	6.4	7.13	7.88	10	500	11.3	134.5	0.061
1N6269A	1N6269CA	1.5KE8.2A	1.5KE8.2CA	7.02	7.79	8.61	10	200	12.1	125.6	0.065
1N6270A	1N6270CA	1.5KE9.1A	1.5KE9.1CA	7.78	8.65	9.50	1.0	50	13.4	113.4	0.068
1N6271A	1N6271CA	1.5KE10A	1.5KE10CA	8.55	9.5	10.5	1.0	10	14.5	104.8	0.073
1N6272A	1N6272CA	1.5KE11A	1.5KE11CA	9.4	10.5	11.6	1.0	5.0	15.6	97.4	0.075
1N6273A	1N6273CA	1.5KE12A	1.5KE12CA	10.2	11.4	12.6	1.0	5.0	16.7	91.0	0.078
1N6274A	1N6274CA	1.5KE13A	1.5KE13CA	11.1	12.4	13.7	1.0	1.0	18.2	83.5	0.081
1N6275A	1N6275CA	1.5KE15A	1.5KE15CA	12.8	14.3	15.8	1.0	1.0	21.2	71.7	0.084
1N6276A	1N6276CA	1.5KE16A	1.5KE16CA	13.6	15.2	16.8	1.0	1.0	22.5	67.6	0.086
1N6277A	1N6277CA	1.5KE18A	1.5KE18CA	15.3	17.1	18.9	1.0	1.0	25.2	60.3	0.089
1N6278A	1N6278CA	1.5KE20A	1.5KE20CA	17.1	19.0	21.0	1.0	1.0	27.7	54.9	0.090
1N6279A	1N6279CA	1.5KE22A	1.5KE22CA	18.8	20.9	23.1	1.0	1.0	30.6	49.7	0.092
1N6280A	1N6280CA	1.5KE24A	1.5KE24CA	20.5	22.8	25.2	1.0	1.0	33.2	45.8	0.094
1N6281A	1N6281CA	1.5KE27A	1.5KE27CA	23.1	25.7	28.4	1.0	1.0	37.5	40.5	0.096
1N6282A	1N6282CA	1.5KE30A	1.5KE30CA	25.6	28.5	31.5	1.0	1.0	41.4	36.7	0.097
1N6283A	1N6283CA	1.5KE33A	1.5KE33CA	28.2	31.4	34.7	1.0	1.0	45.7	33.3	0.098

# 1500W Transient Voltage Suppressor

## 1.5KE6.8A - 1.5KE600CA/1N6267A -1N6303CA

### Electrical Characteristics ( $T_{Ambient}=25^{\circ}C$ unless noted otherwise)

P/N				Stand-Off Voltage	Breakdown Voltage @ Test Current (note1)			Max. Reverse Leakage Current @ V <sub>WM</sub>	Max. Clamping Voltage @ I <sub>PPM</sub>	Max. Peak Pulse Current	Max. Temperature Coefficient of V <sub>BR</sub> (%/°C)
					V <sub>BR</sub>		I <sub>T</sub> (mA)				
Uni-Polar	Bi-Polar	Uni-Polar	Bi-Polar	V <sub>WM</sub> (V)	Min.	Max.		I <sub>D</sub> (μA)	V <sub>C</sub> (V)	I <sub>PPM</sub> (A)	
1N6284A	1N6284CA	1.5KE36A	1.5KE36CA	30.8	34.2	37.8	1.0	1.0	49.9	30.5	0.099
1N6285A	1N6285CA	1.5KE39A	1.5KE39CA	33.3	37.1	41.0	1.0	1.0	53.9	28.2	0.100
1N6286A	1N6286CA	1.5KE43A	1.5KE43CA	36.8	40.9	45.2	1.0	1.0	59.3	25.6	0.101
1N6287A	1N6287CA	1.5KE47A	1.5KE47CA	40.2	44.7	49.4	1.0	1.0	64.8	23.5	0.101
1N6288A	1N6288CA	1.5KE51A	1.5KE51CA	43.6	48.5	53.6	1.0	1.0	70.1	21.7	0.102
1N6289A	1N6289CA	1.5KE56A	1.5KE56CA	47.8	53.2	58.8	1.0	1.0	77.0	19.7	0.103
1N6290A	1N6290CA	1.5KE62A	1.5KE62CA	53.0	58.9	65.1	1.0	1.0	85.0	17.9	0.104
1N6291A	1N6291CA	1.5KE68A	1.5KE68CA	58.1	64.6	71.4	1.0	1.0	92.0	16.5	0.104
1N6292A	1N6292CA	1.5KE75A	1.5KE75CA	64.1	71.3	78.8	1.0	1.0	103.0	14.8	0.105
1N6293A	1N6293CA	1.5KE82A	1.5KE82CA	70.1	77.9	86.1	1.0	1.0	113.0	13.5	0.105
1N6294A	1N6294CA	1.5KE91A	1.5KE91CA	77.8	86.5	95.5	1.0	1.0	125.0	12.2	0.106
1N6295A	1N6295CA	1.5KE100A	1.5KE100CA	85.5	95.0	105.0	1.0	1.0	137.0	11.1	0.106
1N6296A	1N6296CA	1.5KE110A	1.5KE110CA	94.0	105.0	116.0	1.0	1.0	152.0	10.0	0.107
1N6297A	1N6297CA	1.5KE120A	1.5KE120CA	102.0	114.0	126.0	1.0	1.0	165.0	9.2	0.107
1N6298A	1N6298CA	1.5KE130A	1.5KE130CA	111.0	124.0	137.0	1.0	1.0	179.0	8.5	0.107
1N6299A	1N6299CA	1.5KE150A	1.5KE150CA	128.0	143.0	158.0	1.0	1.0	207.0	7.3	0.108
1N6300A	1N6300CA	1.5KE160A	1.5KE160CA	136.0	152.0	168.0	1.0	1.0	219.0	6.9	0.108
1N6301A	1N6301CA	1.5KE170A	1.5KE170CA	145.0	162.0	179.0	1.0	1.0	234.0	6.5	0.108
1N6302A	1N6302CA	1.5KE180A	1.5KE180CA	154.0	171.0	189.0	1.0	1.0	246.0	6.2	0.108
1N6303A	1N6303CA	1.5KE200A	1.5KE200CA	171.0	190.0	210.0	1.0	1.0	274.0	5.5	0.108
-	-	1.5KE220A	1.5KE220CA	185.0	209.0	231.0	1.0	1.0	328.0	4.6	0.108
-	-	1.5KE250A	1.5KE250CA	214.0	237.0	263.0	1.0	1.0	344.0	4.4	0.110
-	-	1.5KE300A	1.5KE300CA	256.0	285.0	315.0	1.0	1.0	414.0	3.7	0.110
-	-	1.5KE320A	1.5KE320CA	273.0	304.0	336.0	1.0	1.0	441.0	3.5	0.110
-	-	1.5KE350A	1.5KE350CA	300.0	332.0	368.0	1.0	1.0	482.0	3.2	0.110

# 1500W Transient Voltage Suppressor

1.5KE6.8A - 1.5KE600CA/1N6267A -1N6303CA

## Electrical Characteristics ( $T_{Ambient}=25^{\circ}C$ unless noted otherwise)

P/N				Stand-Off Voltage	Breakdown Voltage @ Test Current (note1)			Max. Reverse Leakage Current @ V WM	Max. Clamping Voltage @ I PPM	Max. Peak Pulse Current	Max. Temperature Coefficient of VBR (%/° C)
					VBR		IT (mA)				
Uni-Polar	Bi-Polar	Uni-Polar	Bi-Polar	VWM (V)	Min.	Max.		ID (μA)	Vc (V)	IPPM (A)	
-	-	1.5KE400A	1.5KE400CA	342.0	380.0	420.0	1.0	1.0	548.0	2.8	0.110
-	-	1.5KE440A	1.5KE440CA	376.0	418.0	462.0	1.0	1.0	602.0	2.5	0.110
-	-	1.5KE480A	1.5KE480CA	408.0	456.0	504.0	1.0	1.0	658.0	2.3	0.110
-	-	1.5KE510A	1.5KE510CA	434.0	485.0	535.0	1.0	1.0	698.0	2.1	0.110
-	-	1.5KE530A	1.5KE530CA	477.0	503.5	556.5	1.0	1.0	725.0	2.1	0.110
-	-	1.5KE540A	1.5KE540CA	486.0	513.0	567.0	1.0	1.0	740.0	2.0	0.110
-	-	1.5KE550A	1.5KE550CA	495.0	522.5	577.5	1.0	1.0	760.0	2.0	0.110
-	-	1.5KE600A	1.5KE600CA	512.0	570.0	630.0	1.0	1.0	828.0	1.8	0.110

**Note:** (1) For Bi-directional type having Vrwm of 10 volts and less, the IR limit is doubled.  
 (2) For parts without A the VBR is ±10%.

## Typical Characteristics Curves

Fig.1- Peak Pulse Power Rating Curve

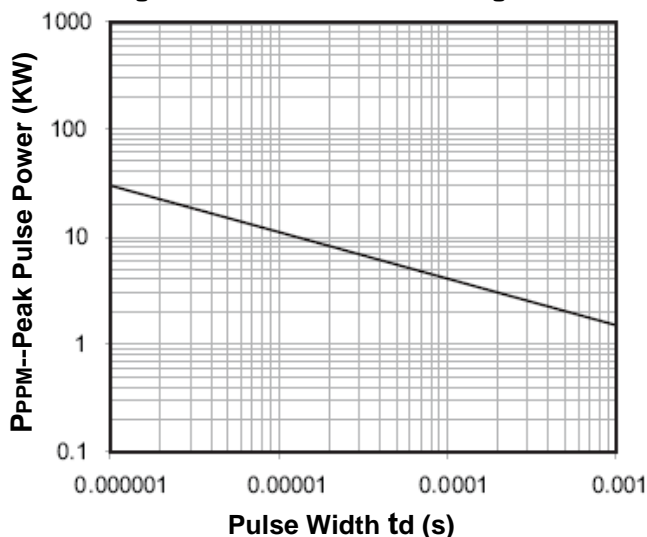
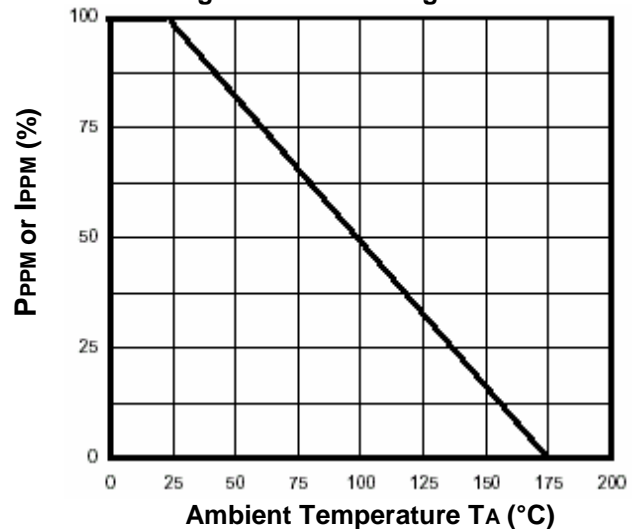

Fig.2- Pulse Derating Curve



# 1500W Transient Voltage Suppressor

1.5KE6.8A - 1.5KE600CA/1N6267A -1N6303CA

Fig.3- Pulse Waveform

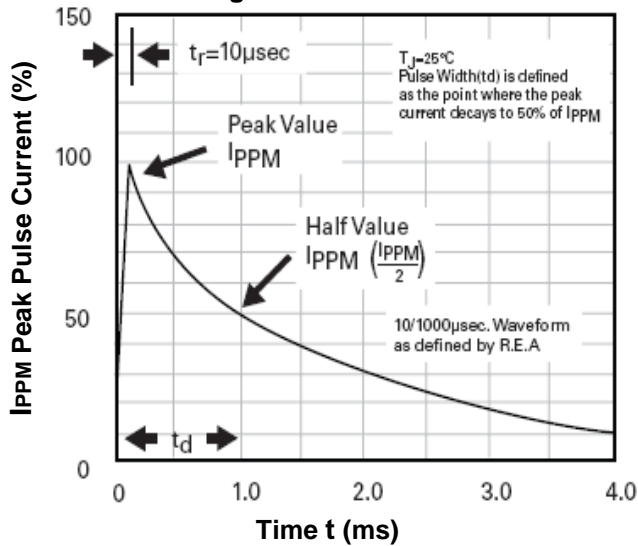

Fig.4- Max. Non-Repetitive Forward Surge Current Uni-directional only

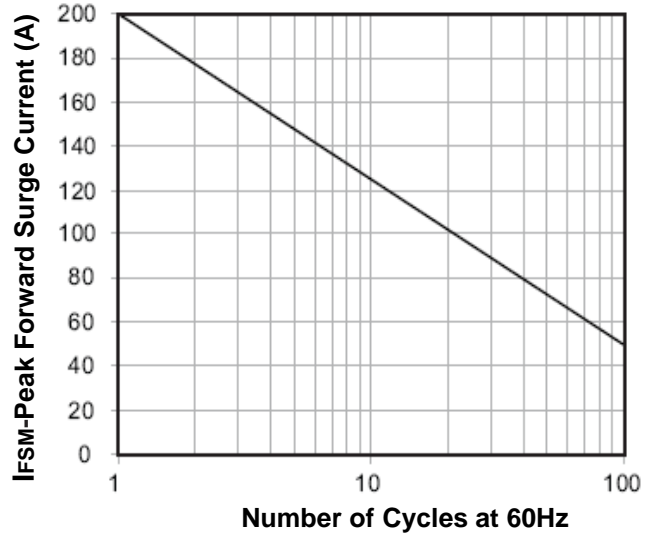

Fig.5- Steady State Power Derating Curve

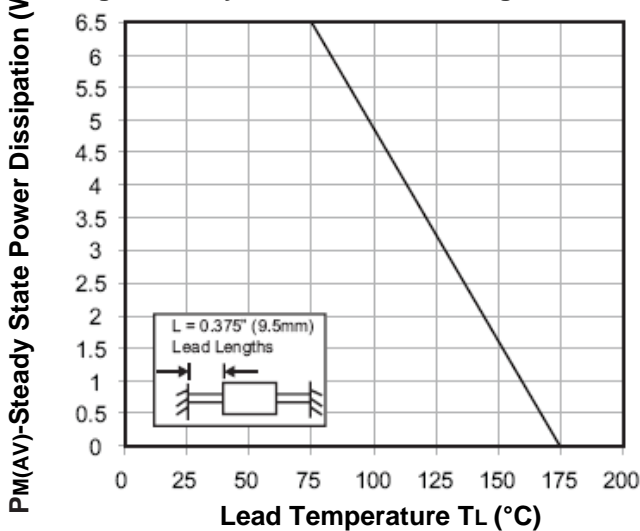
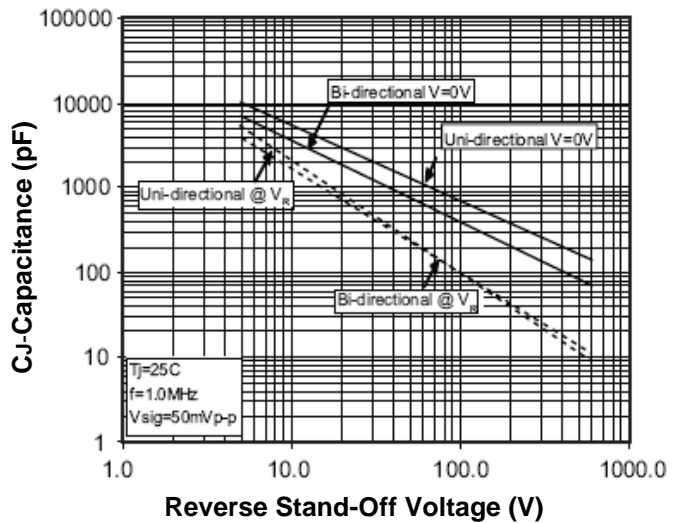

Fig.6- Typical Junction Capacitance



# 1500W Transient Voltage Suppressor

1.5KE6.8A - 1.5KE600CA/1N6267A -1N6303CA

## Marking Information

Uni-directional

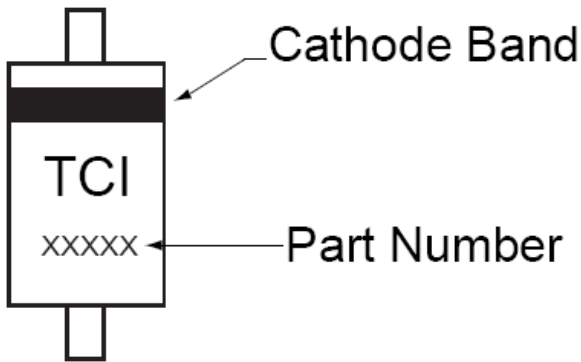

Bi-directional

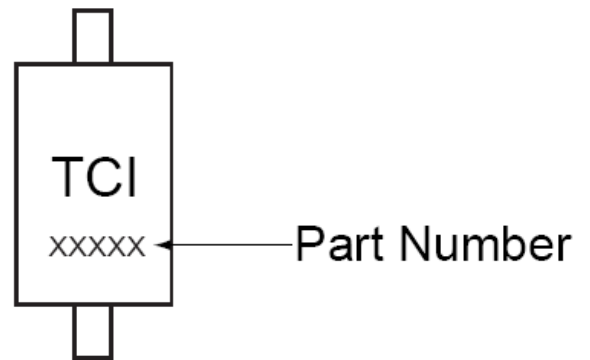

## Dimensions in inch (mm)

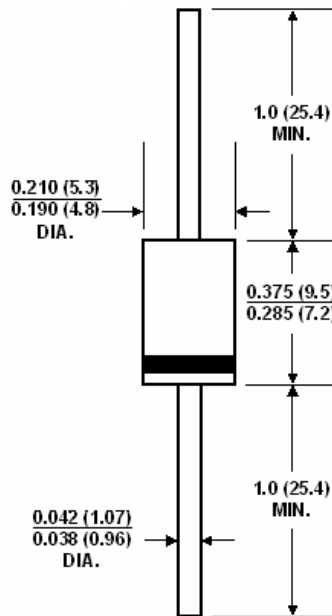

1.5KE

# 1500W Transient Voltage Suppressor

1.5KE6.8A - 1.5KE600CA/1N6267A -1N6303CA

## Packing Information:

### Carrier Tape Dimensions (in mm)

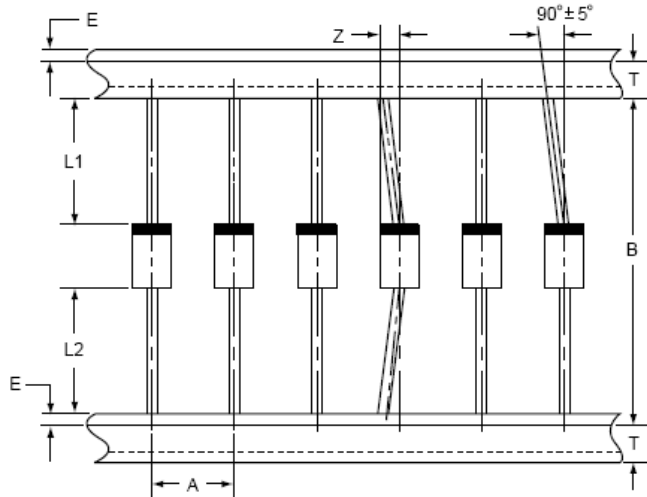

Components Outline	A	B	L1- L2	T	E	Z
1.5KE	10±0.5	52.4±1	Max.1.0	6±0.4	Max.0.8	Max.1.2

### Reel Dimensions (in mm)

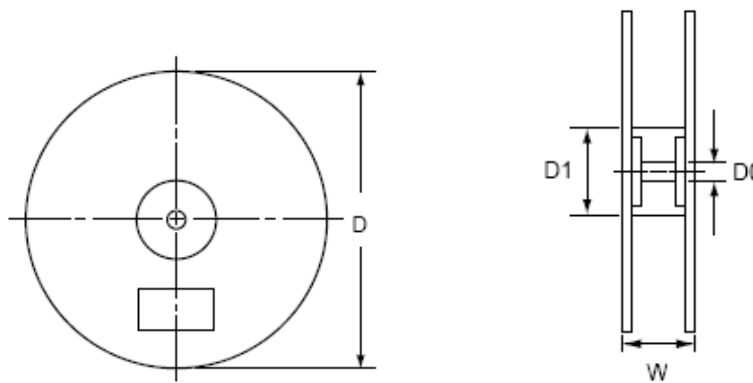

D	D0	D1	W
330.0±2.0	16.6±0.4	85.7±0.3	79.0±1.0

# 1500W Transient Voltage Suppressor

1.5KE6.8A - 1.5KE600CA/1N6267A -1N6303CA

## Packing Quantity Information:

Quantity	PCS per Inner Box	PCS per Carton
13' Tape & Reel	1400/Reel	5600

## Carton Size Information: (in mm)

Carton Size
350X350X350

## How to Order

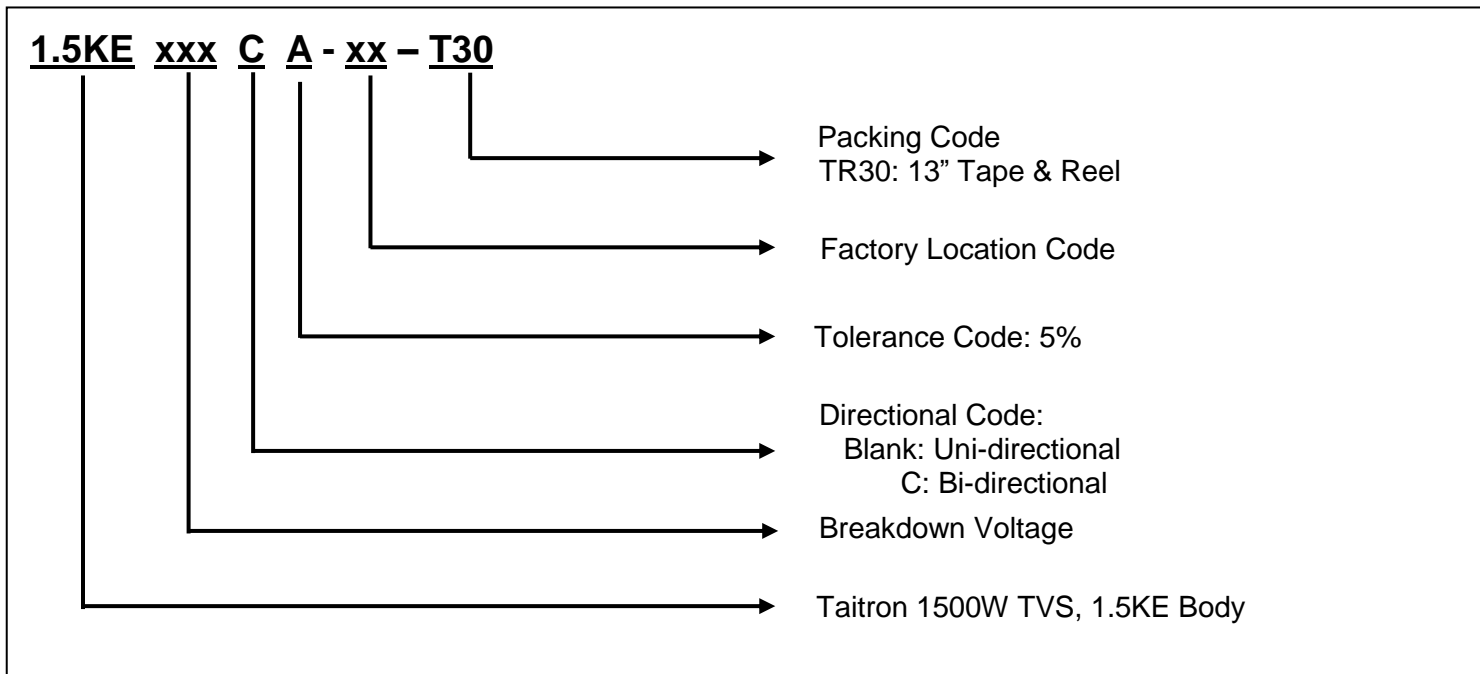



# 1500W Transient Voltage Suppressor

1.5KE6.8A - 1.5KE600CA/1N6267A -1N6303CA

## How to contact us:

### USA HEADQUARTERS

28040 WEST HARRISON PARKWAY, VALENCIA, CA 91355-4162

Tel: (800)-TAITRON (800)-824-8766 (661)-257-6060

Fax: (800)-TAITFAX (800)-824-8329 (661)-257-6415

Email: [taitron@taitroncomponents.com](mailto:taitron@taitroncomponents.com)

Http://[www.taitroncomponents.com](http://www.taitroncomponents.com)

### TAITRON COMPONENTS INCORPORATED TAIWAN BRANCH

6F., NO.190, SEC. 2, ZHONGXING RD., XINDIAN DIST., NEW TAIPEI CITY 23146, TAIWAN R.O.C.

Tel: 886-2-2913-6238

Fax: 886-2-2913-6239

### TAITRON COMPONENT TECHNOLOG SHANGHAI CORPORATION

SUITE 1503, METROBANK PLAZA, 1160 WEST YAN'AN ROAD, SHANGHAI, 200052, CHINA

Tel: +86-21-5424-9942

Fax: +86-21-2302-5027